

SC/SE Series

Wash Down Scales

SC-30KAM / SC-60KAM / SC-150KAM / SC-60KAL / SC-150KAL

SE-30KAM / SE-60KAM / SE-150KAM / SE-60KAL / SE-150KAL

INSTRUCTION MANUAL



© 2010 A&D Company, Limited. All rights reserved.

No part of this publication may be reproduced, transmitted, transcribed, or translated into any language in any form by any means without the written permission of A&D Company, Limited.

The contents of this manual and the specifications of the instrument covered by this manual are subject to change for improvement without notice.

CONTENTS

1. INTRODUCTION	2
2. FEATURES	2
3. UNPACKING	3
4. DESCRIPTION OF EACH PART	4
4-1. Display and symbols	6
4-2. Switches.....	7
5. SETTING UP	8
5-1. Attaching the display pole to the base	8
5-2. Installing the scale.....	10
5-3. Installing the batteries	11
6. BASIC OPERATION	12
6-1. Turning the power ON and OFF	12
6-2. Selecting a weighing unit.....	12
6-3. Basic weighing operation	13
6-4. Weight display resolution	13
7. COUNTING MODE	14
8. COMPARATOR	15
9. CALIBRATION	17
9-1. Gravity acceleration correction.....	17
9-2. Calibration using a weight	18
9-3. Restoring to the factory setting values	19
10. FUNCTIONS	20
10-1. Setting the parameters.....	20
10-2. Function list	21
11. OPTIONS	22
12. MAINTENANCE	22
12-1. Notes on maintenance	22
12-2. Error codes.....	22
13. SPECIFICATIONS	23
13-1. Specifications	23
13-2. External dimensions	24
GRAVITY ACCELERATION MAP	26

1. INTRODUCTION

This manual describes how the SC/SE Series Wash Down Scales work and how to get the most out of them in terms of performance. Please read this manual completely before using the scale.

2. FEATURES

The SC/SE Series Wash Down Scales have the following features:

- Dust-tight and water-tight construction, complying with IP68.
Water will not enter the scale even if immersed to a depth of 1 m for 24 hours.
- The weighing platform of the SC series is made of stainless steel (SUS304), and the SE series, steel.
The weighing pan of both models is made of stainless steel (SUS430).
- As a power source, size D batteries are used. The battery life, when Alkaline batteries are used, is approximately 3,600 hours.
- A large LCD with a character height of 39 mm is used.
- Two weighing platform sizes are available. The SC-KAL and SE-KAL series have a larger weighing pan, and the SC-KAM and SE-KAM series have a smaller weighing pan. Select a model that suits your own application.
- Two types of weight display resolution are available, normal (1/3,000) and high (1/6,000 or 1/7,500).
- The counting function easily counts the number of objects of the same weight.
- The comparator function compares the displayed value (weight value) with the upper and lower limit values and shows the results. The optional OP-03 (SCE-03) comparator relay output can output the results as a relay signal.
- The optional OP-02 (SCE-02) USB interface and OP-03 (SCE-03) RS-232C serial interface can transmit the weight value to a personal computer.

3. UNPACKING

When unpacking, check whether all of the following items are included:

● Instruction manual

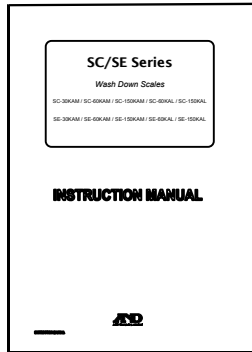

● SC-KAL / KAM series

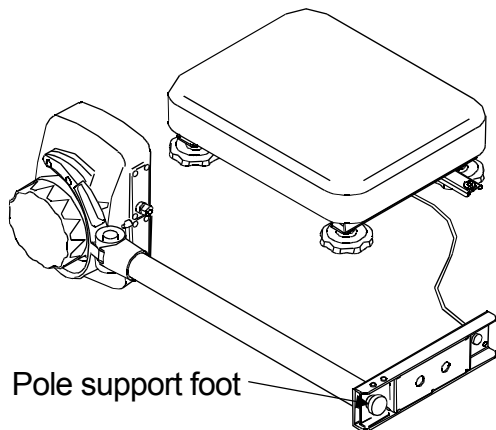

● SE-KAL / KAM series

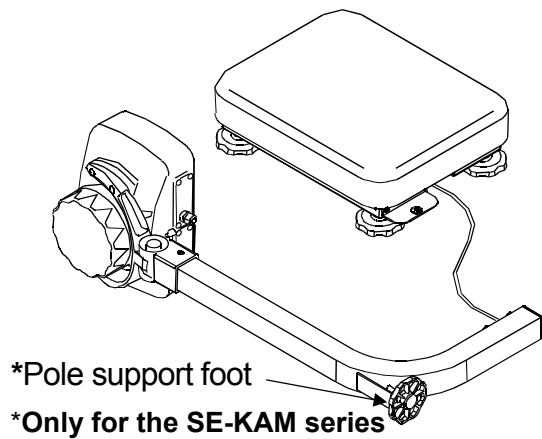

□ The cable length from the base to the display is approximately 1.5 m.

4. DESCRIPTION OF EACH PART

● SC-KAL / KAM series

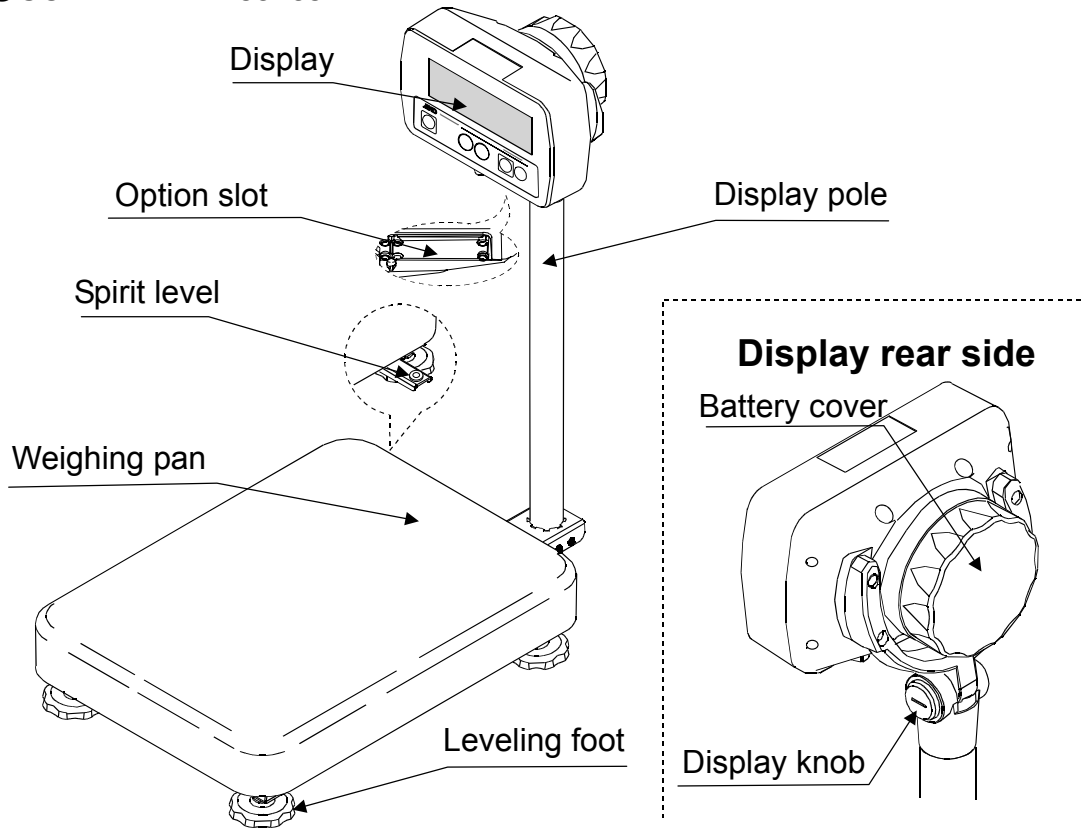

● SE-KAL / KAM series

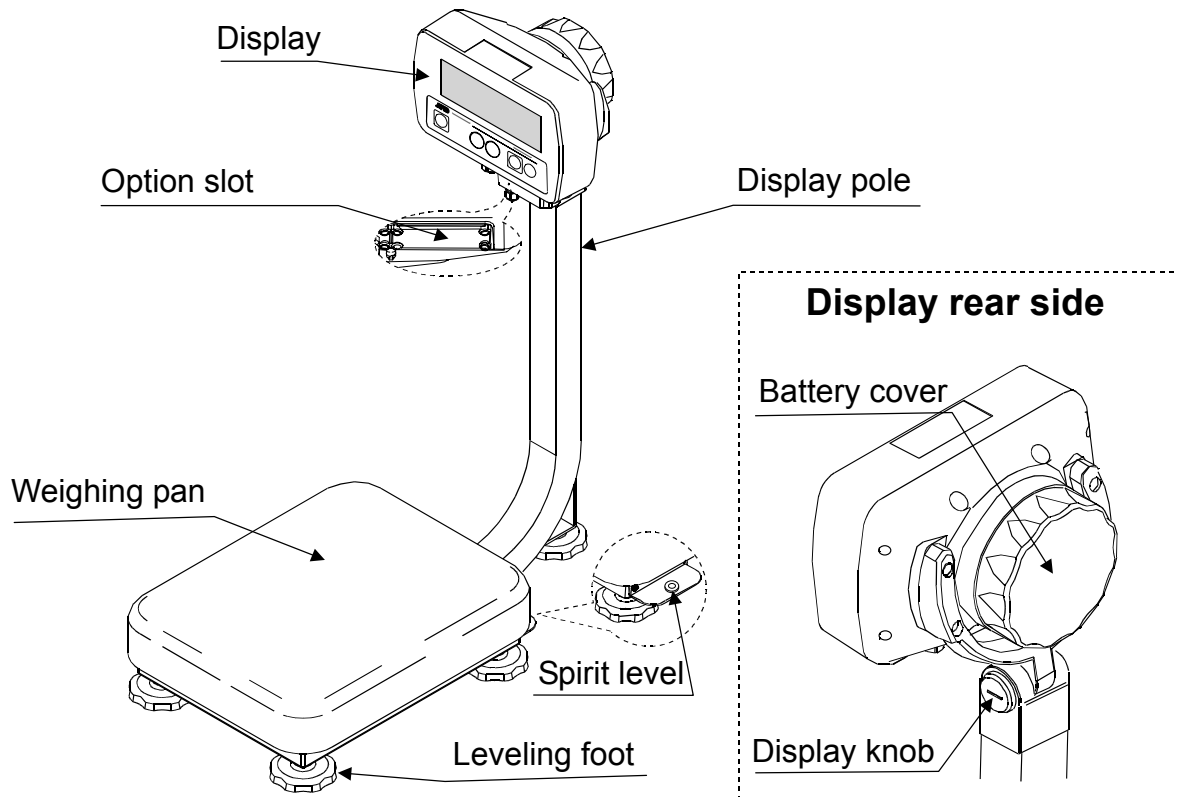

4-1. Display and symbols



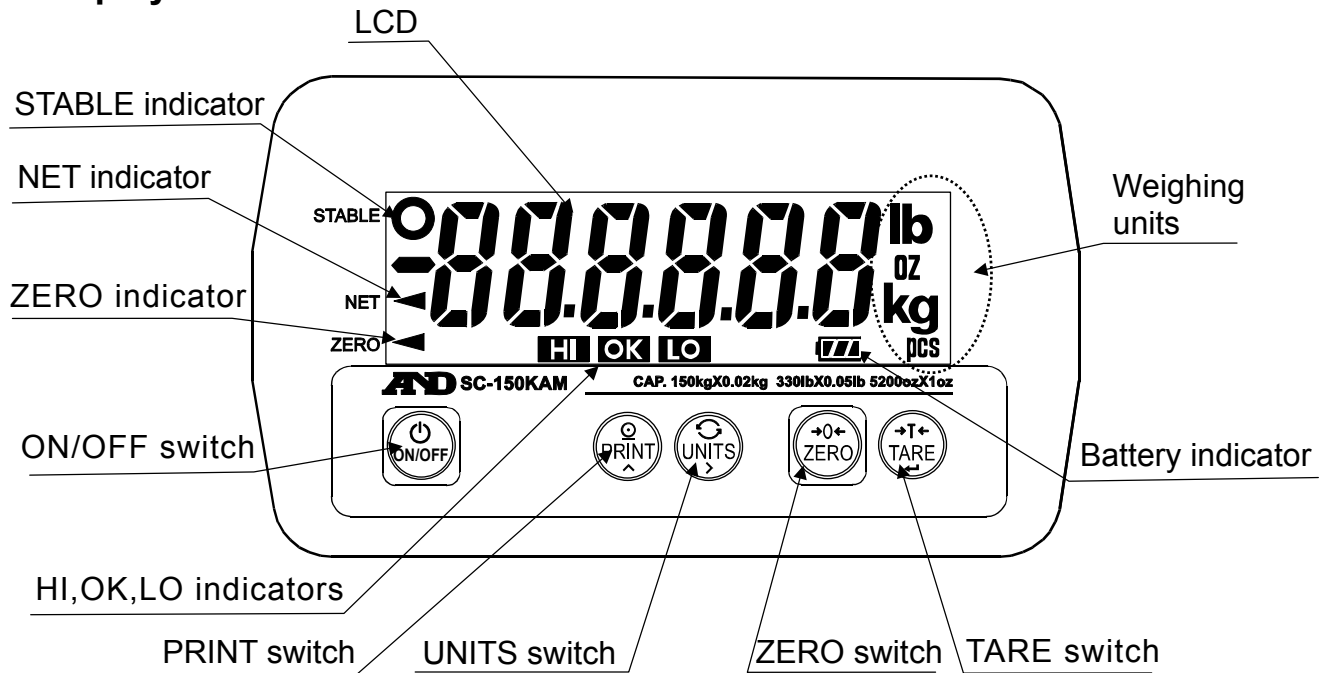

Display

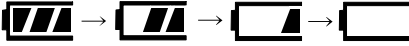

Symbols

Symbol	Description
STABLE ○	Turns on when the weight value is stable.
NET ◀	Turns on when the NET weight is displayed. (The tare operation is in progress.)
ZERO ◀	Turns on when the scale shows zero.
HI OK LO	Turns on when the comparator results are displayed.
Weighing units	"lb", "oz", "kg" and "pcs" are available. A selected unit turns on.
 Battery indicator	The battery indicator changes as the battery capacity decreases, as shown below:  New → Replace the batteries.

4-2. Switches

Switch	Description
	<u>ON/OFF switch</u> Turns the power ON or OFF. When turned ON, the scale will be automatically set to zero (power-on zero).
	<u>PRINT switch</u> Outputs the weight value to the printer. In the setting mode, this switch is used to increase the value of the selected blinking digit by one.
	<u>UNITS switch</u> Switches the weighing unit. In the setting mode, this switch is used to shift the blinking digit to the right.
	<u>ZERO switch</u> Zeroes the scale and sets the display to zero.
	<u>TARE switch</u> Subtracts the tare (container) weight placed on the weighing pan. In the setting mode, this switch is used to store the setting value and proceed to the next step.

- The **ZERO** and **TARE** switches work when the weight value is stable.
- The **ZERO** switch will zero the scale if the weight value is within $\pm 2\%$ of the weighing capacity (kg) around the power-on zero point. The ZERO ◀ indicator turns on. (ZERO operation)
- The **TARE** switch will tare the scale and subtract the weight to zero as a tare weight when the weight is a plus value. In this case the ZERO ◀ and NET ◀ indicators turn on. (TARE operation)
When the tare is removed while the tare operation is in progress and the scale returns to the zero point, the ZERO ◀ and NET ◀ indicators turn on. In this case the displayed tare value will be negative.
- When the tare is removed while the tare operation is in progress and the ZERO operation described above is performed, the tare operation previously done is cleared and the NET ◀ indicator turns off.

5. SETTING UP

5-1. Attaching the display pole to the base

SC-KAL / KAM series

1. Remove the weighing pan from the base.
2. Remove the 4 screws from the lower part of the display pole.
3. Insert the display pole under the base while pulling out the cable into the base and align the cable opening positions of the pole and the base. (See "3" in the illustration.)
- ❑ **Do not pull the cable forcibly. Take care not to pinch the cable between the pole and the base.**
4. Align the screw holes of the pole and the base. Using the 4 screws removed at step 2 to secure the display pole to the base firmly.

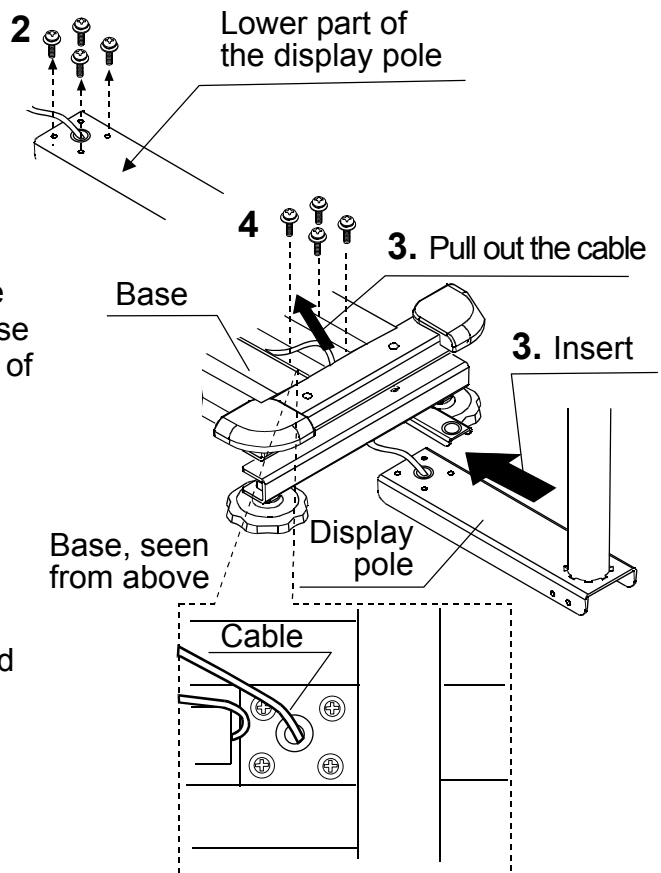

5. Lay the base on its side. Remove the 4 screws ("5" in the illustration) and remove the pole support foot.

6. Pull the excess cable out of the base. (See "6" in the illustration.)

- ❑ **Take care not to damage the cable. And make sure the cable has no slack.**

7. Pull the cable out to the pole side. (See "7" in the illustration.)

8. Put the bundle of cable back into the display pole. (See "8" in the illustration.)

9. Using the 4 screws removed at step 5 to secure the pole support foot to the display pole.

10. Return the base to the upright position and place the weighing pan on the base.

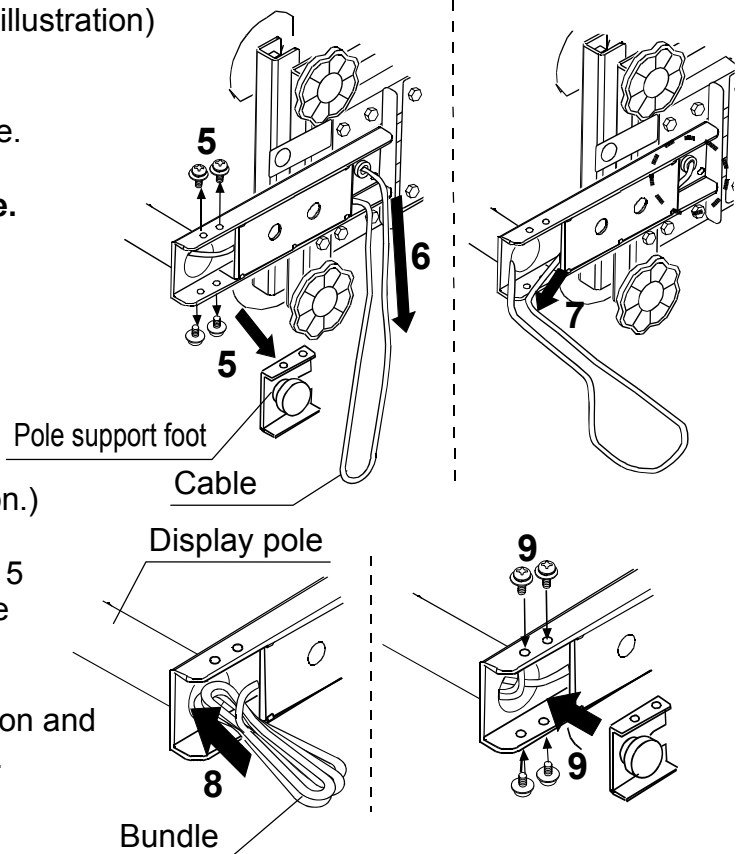

SE-KAL / KAM series

1. Remove the weighing pan from the base.
 2. Remove the 4 screws from the lower part of the display pole.
 3. Insert the display pole under the base while pulling out the cable into the base and align the cable opening positions of the pole and the base. (See “3” in the illustration.)
- ❑ Do not pull the cable forcibly. Take care not to pinch the cable between the pole and the base.**
4. Align the screw holes of the pole and the base. Using the 4 screws removed at step 2 to secure the display pole to the base firmly.

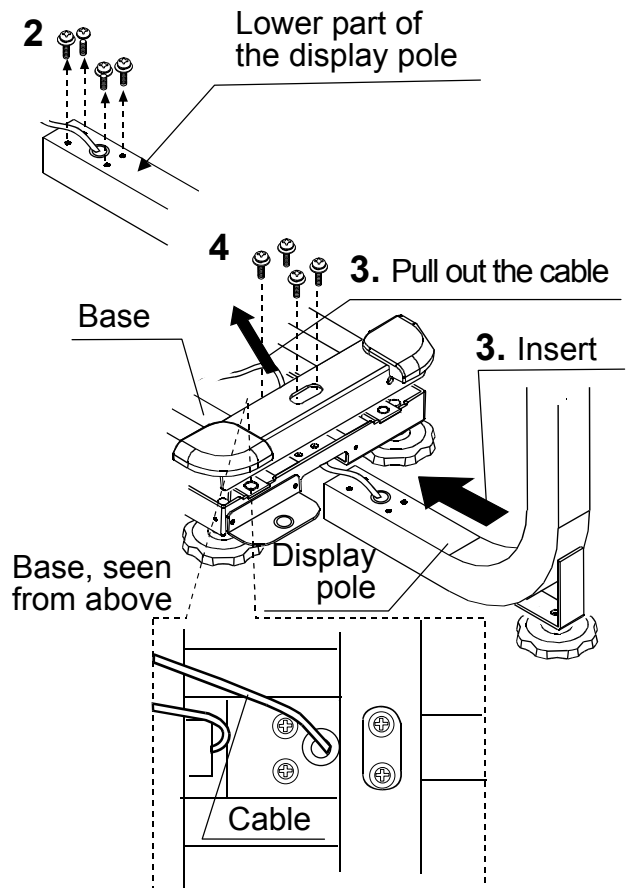

5. Turn the display knob counterclockwise to remove the display from the display pole. (“5” in the illustration)
 6. Pull the excess cable, from inside the base, out of the display pole. (See “6” in the illustration.)
- ❑ Take care not to damage the cable. And make sure the cable has no slack.**

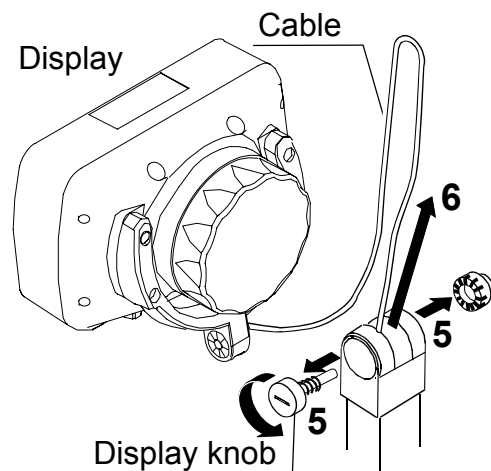

7. Put the bundle of cable back into the display pole. (See “7” in the illustration.)
8. Place the display on the pole and secure it using the display knob. (See “8” in the illustration.)
9. Place the weighing pan on the base.

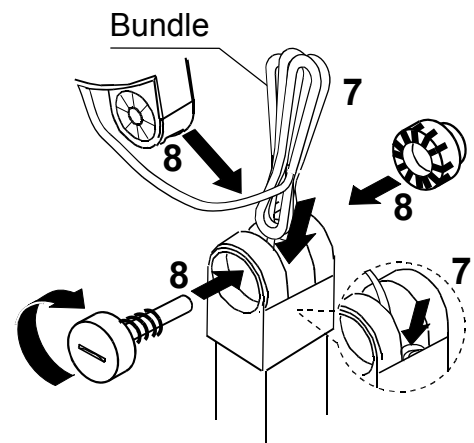

5-2. Installing the scale

1. Select the place for installing the scale. Refer to “Precautions on installing the scale” below.
2. Adjust the level of the base, using the spirit level and leveling feet. Confirm that the bubble is in the center of the level.
The SE-KAM series has an extra foot at the bottom of the display pole. Adjust this foot to touch the floor after adjusting the level of the base.

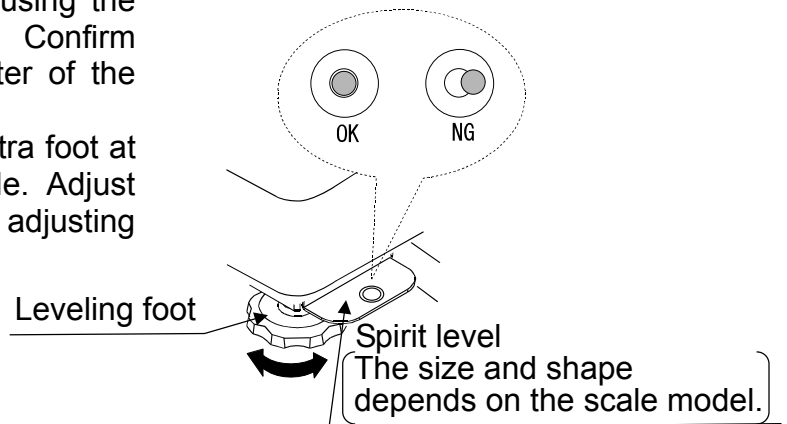

3. Press in on the display knob located at the lower part of the display to tilt the display to an appropriate angle, 0°, 30° or 60°.

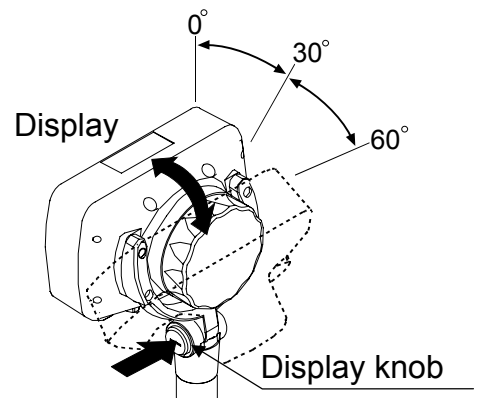

Precautions on installing the scale

Consider the following conditions to get the most out of the scale.

- Install the scale where the temperature and relative humidity are stable and where there is no draft or vibration.
- Installing the scale or storing it for an extended period where the temperature and relative humidity are high and where there may be abrupt changes in temperature may cause scale failure.
- Install the scale on a solid and level surface.
- Do not install the scale in direct sunlight.
- Do not install the scale near heaters or air conditioners.
- Do not install the scale where flammable or corrosive gas is present.
- Do not install the scale near equipment which produces magnetic fields.
- Do not install the scale where there is apt to be static electricity, in a place where the relative humidity is lower than 45% RH. Insulators such as plastic are apt to be charged with static electricity.
- When the scale is installed for the first time, or the scale has been moved, perform calibration as described in “9. CALIBRATION”.

5-3. Installing the batteries

Prepare six, size D (R20P or LR20) batteries. The batteries are not included with the product.

The scale can be used continuously for about 3,600 hours using alkaline batteries. When  appears, replace all six batteries with new ones as soon as possible.

1. Turn the battery cover on the rear of the display counterclockwise to remove it.
2. Press on the catch in the arrow direction to release it. Take the battery compartment out in the direction of the arrow.
3. While taking care of the battery polarity, insert a battery into the battery compartment. The polarity marks are shown in the battery compartment. First, insert the negative side of the battery into the compartment. Press down the positive side to fit into the compartment, as shown to the right.
 To remove the battery, reverse the procedure above. First, push in on the positive side toward to the negative side.
4. Insert six new batteries in the battery compartment as described in step 3.
5. Place the battery compartment back into the display, using the positioning tab as a guide. Secure the catch into the hole with a clicking sound.
6. Turn the battery cover clockwise to attach it. Make sure that the groove on the cover is correctly engaged and the cover is closed completely.

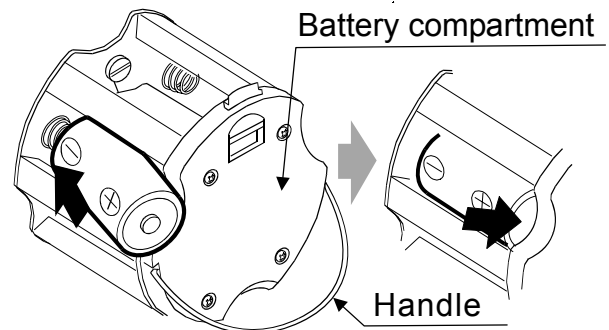
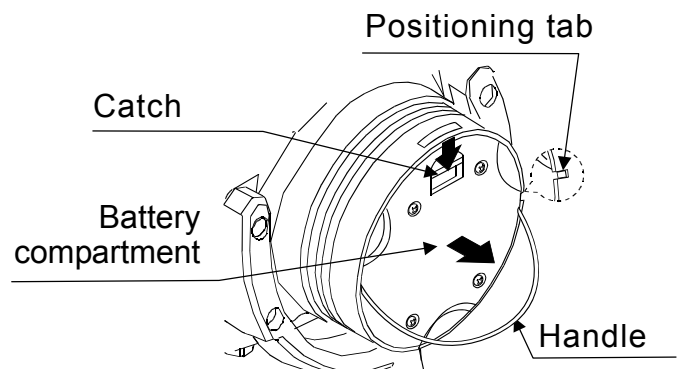
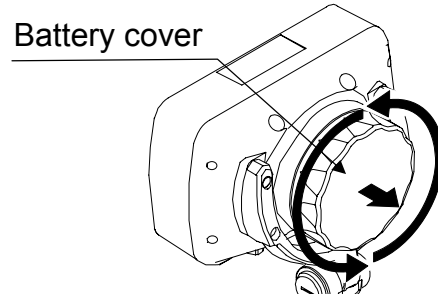

Precautions on using the batteries

- Do not handle the batteries with wet hands. Do not allow the batteries to become wet.
- Take great care of the polarity of batteries. The polarity marks are shown in the battery compartment.
- Replace the batteries with six new ones when “L b” is displayed.
- Do not mix used and new batteries. It may cause damage to the batteries or product, if used.
- Do not mix the battery type. It may cause damage to the batteries or product.
- The battery life depends on the ambient temperature.
- Remove the batteries from the battery compartment if the scale is not to be used for a long period of time. They may leak and cause damage. Damage due to battery leakage is not covered by the warranty.

6. BASIC OPERATION

6-1. Turning the power ON and OFF

1. Press the **ON/OFF** switch to turn the power ON.

All the display symbols appear and the scale waits for the weight value to become stable.

After the weight value internally becomes stable, the display turns off for a moment and zero is shown with the ZERO indicator (power-on zero).

If the weight value is unstable, the display shows “-----”. Check if anything touches the weighing pan, or check if there is strong wind or vibration. And eliminate the cause of the error.

The range for power-on zero is within $\pm 50\%$ of the weighing capacity (kg) around the calibrated zero point.

If the power is turned ON while there is a load beyond this range, the scale shows “-----”. Remove the load from the weighing pan.

- If the scale is to be turned ON with some item loaded, performing a zero calibration with the item loaded will allow the scale to turn ON that way. (Refer to “9. CALIBRATION”.) In this case, make sure that the total weight of the item loaded at power-on and the object to be weighed is within the weighing capacity.

2. Press the **ON/OFF** switch to turn the power OFF.

- Auto power-off function

The auto power-off function automatically turns the power OFF, if zero is displayed for approximately 5 minutes.

Refer to “10-2. Function list” to set “POFF”. The auto power-off function has been enabled at the factory.

6-2. Selecting a weighing unit

In the weighing mode, press the **UNITS** switch to select a weighing unit.

Each time the **UNITS** switch is pressed, the unit changes as shown below.

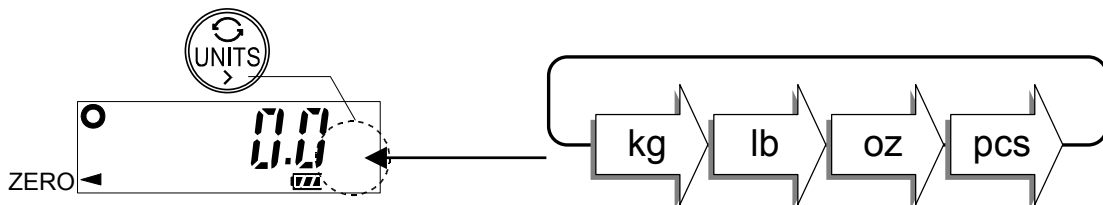

6-3. Basic weighing operation

1. Press the **ON/OFF** switch to turn the power ON.
2. Select a weighing unit using the **UNITS** switch.
3. When the display doesn't show zero, press the **ZERO** switch to set the display to zero.
4. When using a tare (container), place the container on the weighing pan, and press the **TARE** switch to set the display to zero.
5. Place the object to be weighed on the weighing pan or in the container, and wait for the STABLE indicator to turn on and read the value.
6. Remove the object from the weighing pan.

- The **ZERO** switch will zero the scale if the weight value is within $\pm 2\%$ of the weighing capacity (kg) around the power-on zero point. The ZERO \blacktriangleleft indicator turns on. If the weight value exceeds $\pm 2\%$ of the weighing capacity (kg), the **ZERO** switch does not work.
- The **TARE** switch will tare the scale and subtract the weight to zero as a tare weight when the weight is a plus value.
- Weighing is possible up to the weighing capacity. When a tare is used, weighing is possible up to the weighing capacity less the tare weight value.

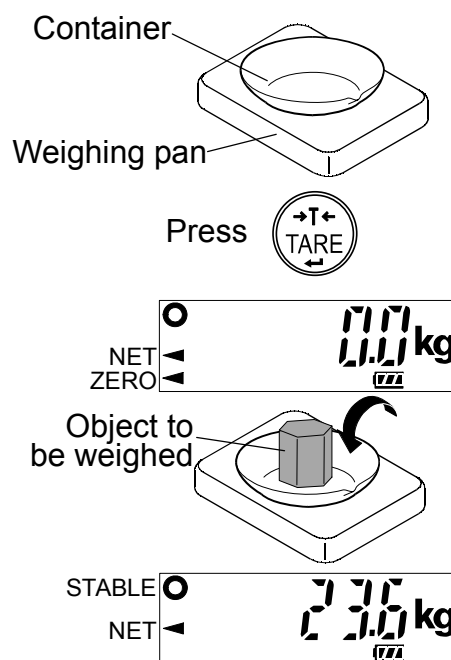

Precautions during operation

- When reading or storing a value, make sure that the **STABLE** indicator is turned on.
- Do not press switches with a sharp instrument such as a pencil.
- Do not apply a shock load to the scale.
- Do not place a load on the weighing pan that exceeds the weighing capacity.
- Keep the scale free from foreign objects.
- Calibrate the scale periodically to keep weighing accuracy. (Refer to "9. CALIBRATION".)

6-4. Weight display resolution

The weight display resolution is a ratio of the minimum display to the weighing capacity. The SC/SE series has two types of weight display resolution, normal and high.

Normal: 1/3,000
High: 1/6,000 or 1/7,500 (depending on the weighing capacity)

The factory setting is the high resolution. Select the resolution that suits your own application by the function setting "r5Ea".

- For details about the minimum display and the weighing capacity, refer to "13-1. Specifications".
- In the counting mode, the scale works with the high resolution regardless of the weight display resolution selected by the function setting "r5Ea".

7. COUNTING MODE

Determines a unit weight (the weight of one piece) from the known pieces of samples, and calculates how many pieces are on the weighing pan using the unit weight. The unit weight is maintained even if the power is turned OFF.

1. Press the **UNITS** switch to select "pcs".
("pcs" = pieces)



2. Press and hold the **UNITS** switch to enter the sample unit weight storing mode. The numerical value on the left indicates the number of samples.

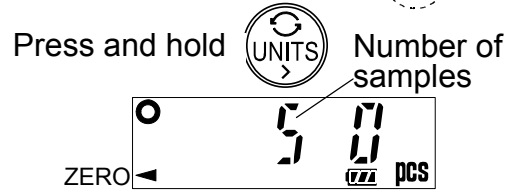

3. To change the number of samples, press the **PRINT** switch. It may be set to 5, 10, 20, 50 or 100.

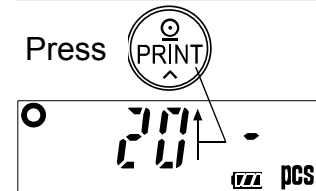

4. If necessary, place a container on the weighing pan, and press the **TARE** switch. Confirm that the right side of the number of samples shows zero.

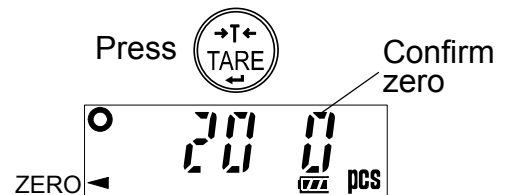
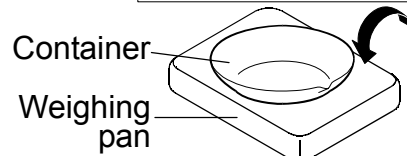

5. Place the correct number of samples on the weighing pan or in the container.

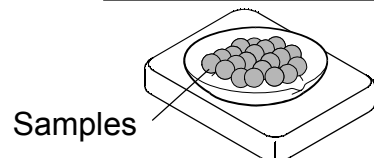

6. Confirm that the **STABLE** indicator is turned on. Press the **UNITS** switch to calculate and store the unit weight. Remove the samples. The scale is set to count objects with this unit weight.

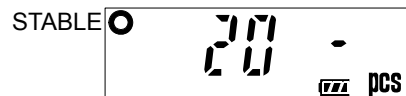

❑ The total weight of samples should be more than shown below, regardless of the number of samples.

- Weighing capacity of 30 kg: 0.05 kg
- Weighing capacity of 60 kg: 0.1 kg
- Weighing capacity of 150 kg: 0.2 kg

If not, the display shows "Lo Ut" and returns to the display of step 5. Increase the number of samples (step 3) and try again.

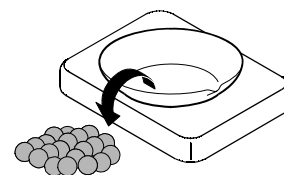

7. Place the objects to be counted on the weighing pan.

8. COMPARATOR

Compares the weight value with the upper and lower limit values and shows the results of the comparison by **HI** **OK** **LO** on the display.

The formula to compare is as follows:

$$\mathbf{LO} < \text{Lower limit value} \leq \mathbf{OK} \leq \text{Upper limit value} < \mathbf{HI}$$

Select comparison conditions that suit your own application. (Refer to “Comparator mode: [P]” in “10-2. Function list”.)

- 0: No comparison (comparator function disabled).
 - 1: To compare all data.
 - 2: To compare all stable data.
 - 3: To compare all data which are more than +4d or less than -4d.
 - 4: To compare stable data which are more than +4d or less than -4d.
 - 5: To compare all data which are more than +4d.
 - 6: To compare stable data which are more than +4d.
- d = minimum display (Refer to “13-1. Specifications”.)

Also in the counting mode, “d” is equal to the minimum display of kg mode.

- The upper and lower limit values are maintained even if the power is turned OFF.
- The upper and lower limit values are common to the weighing and counting mode.
- Ignore the decimal point when setting the upper limit or lower limit value.

For example, when the weighing capacity is 30 kg and the setting value is “001000”:

Display mode	Limit value	Capacity / Minimum display
Normal resolution kg	10.00 kg	30.00 kg / 0.01 kg
High resolution kg	1.000 kg	30.000 kg / 0.005 kg
Normal resolution lb	10.00 lb	66.00 lb / 0.02 lb
High resolution lb	10.00 lb	66.00 lb / 0.01 lb
Normal resolution oz	100.0 oz	1050.0 oz / 0.5 oz
High resolution oz	100.0 oz	1050.0 oz / 0.2 oz
Counting mode	1000 pcs	

Entering the upper and lower limit values

1. Press the **UNITS** switch to select a weighing unit, "kg", "lb" or "oz"
2. Press and hold the **UNITS** switch to enter the upper limit setting mode.
3. Enter the upper limit value using the following switches.

UNITS To shift the blinking digit to the right.

PRINT To increase the value of the blinking digit by one.

The minus sign can be selected as a blinking digit after the least significant digit.

The **PRINT** switch alternates the minus sign on and off. The blinking "-" shows minus and no sign is plus.

4. After setting all of the digits, press the **TARE** switch. Then, the upper limit value is stored and the display goes to the lower limit setting mode.
5. Set the lower limit value in the same way as the upper limit value setting procedure, and press the **TARE** switch to return to the weighing mode.

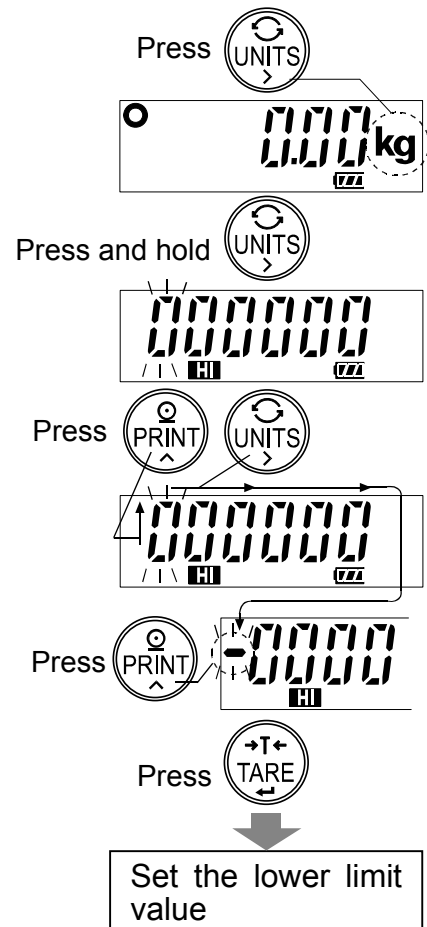

9. CALIBRATION

Adjusts the scale for accurate weighing.
Calibrate the scale in the following cases.

- When the scale is first installed.
- When the scale has been moved.
- When the ambient environment has changed.
- For regular calibration.

9-1. Gravity acceleration correction

When the scale is first used or has been moved to another location, it should be calibrated using a calibration weight.

But if a calibration weight is not available, the gravity acceleration correction will compensate the scale. Change the gravity acceleration value stored in the scale to the value of the area where the scale will be used. Refer to the gravity acceleration map at the end of this manual.

Note

Gravity acceleration correction is not required when the scale will be calibrated using a calibration weight at the place where it is to be used.

- Make sure that the scale is in the weighing mode (displaying “kg”, “lb”, “oz” or “pcs”).

1. Press and hold the **TARE** switch until the gravity acceleration value (in this example: 9.7985) appears, and release the switch.
2. Press and hold the **UNITS** switch until the value starts to blink.
3. Change the displayed value using the following switches.

UNITS To shift the blinking digit to the right.

PRINT To increase the value of the blinking digit by one.

4. Press the **TARE** switch. The setting value is stored and “End” is displayed.
5. When calibration using a calibration weight is to be performed, go to step 3 of “9-2. Calibration using a weight”. To finish the setting procedure, turn the power OFF.

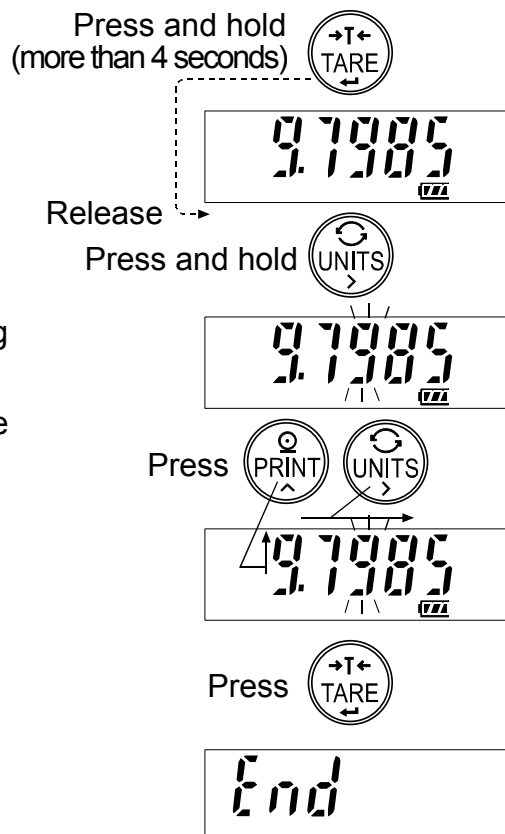

9-2. Calibration using a weight

Prepare a weight, preferably a weight with the same value as the weighing capacity of the scale to be calibrated. Note that the calibration weight value can be set by 10 kg/lb.

- Turn the power ON and warm up the scale for at least half an hour.
 - Change the function setting "POFF" or place something on the weighing pan to disable the auto power-off function.
 - Make sure that the scale is in the weighing mode (displaying "kg", "lb", "oz" or "pcs").
- Press and hold the **TARE** switch until the gravity acceleration value appears, and release the switch.
- Press the **UNITS** switch and display "CAL".
- Press and hold the **UNITS** switch until "CAL 0" is displayed. Confirm that nothing is placed on the weighing pan and wait for the STABLE indicator to turn on.
- Press the **TARE** switch. The scale calibrates the zero point and displays the value of the calibration weight (SPAN calibration).
 - The calibration weight value is equal to the weighing capacity. (factory setting)
 - If SPAN calibration is not to be performed, turn the power OFF to exit from the calibration procedure.
- To calibrate with a weight different from the weighing capacity, change the displayed value using the following switches.

UNITS To shift the digit that is blinking (unit of measure included) to the right.

PRINT To increase the value of the blinking digit by one or to switch the unit between kg and lb.

- Place the calibration weight with the same value as displayed on the weighing pan, and wait for the STABLE indicator to turn on.
- Press the **TARE** switch. The scale calibrates SPAN and "End" is displayed.

Remove the weight from the weighing pan, and turn the power OFF.

Note

If the scale will be moved to another location, set the gravity acceleration value for the new location and calibrate the scale according to the procedure above. Refer to the previous section to set the gravity acceleration value.

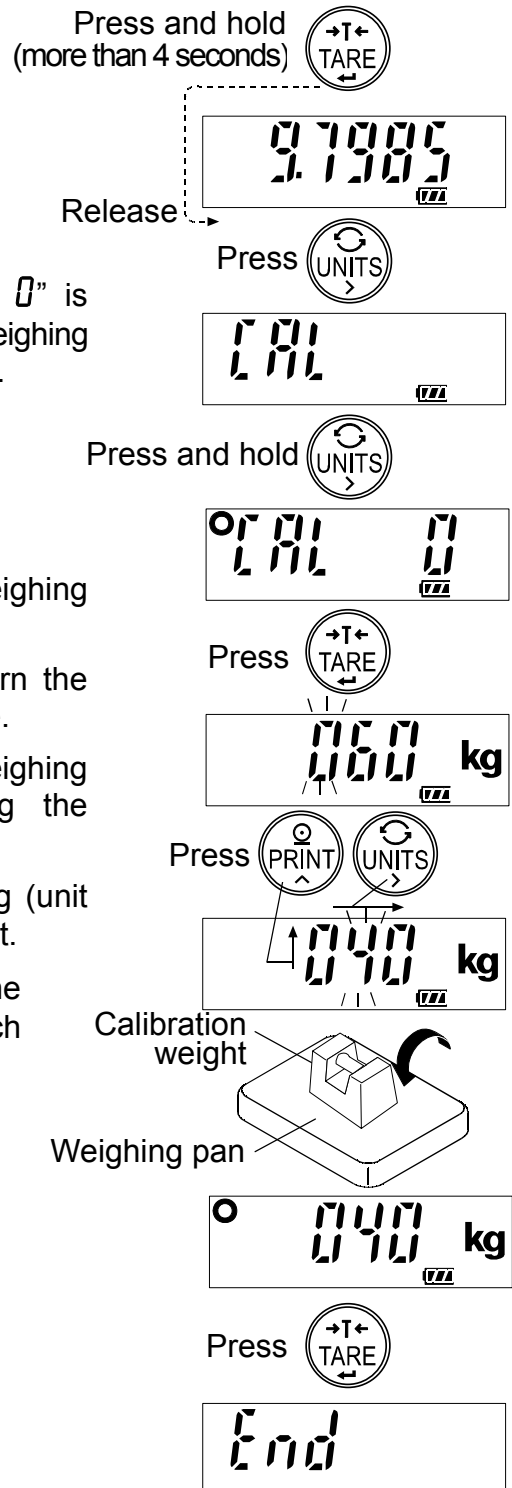

9-3. Restoring to the factory setting values

If the gravity acceleration value or calibration weight value is changed unintentionally, restore those values to the factory setting values, as follows.

☐ Make sure that the scale is in the weighing mode (displaying “kg”, “lb”, “oz” or “pcs”).

1. Press and hold the **TARE** switch until the gravity acceleration value appears, and release the switch.
2. Press the **UNITS** switch twice and display “**LLrL**” .
3. Press and hold the **UNITS** switch until “**LLrLno**” appears blinking.
4. Press the **PRINT** switch.
“**LLrLno**” changes to “**LLrLGo**”.
5. When “**LLrLGo**” is displayed, press the **TARE** switch. The factory setting values are restored and “**End**” is displayed.

To finish the restoring procedure, turn the power OFF.

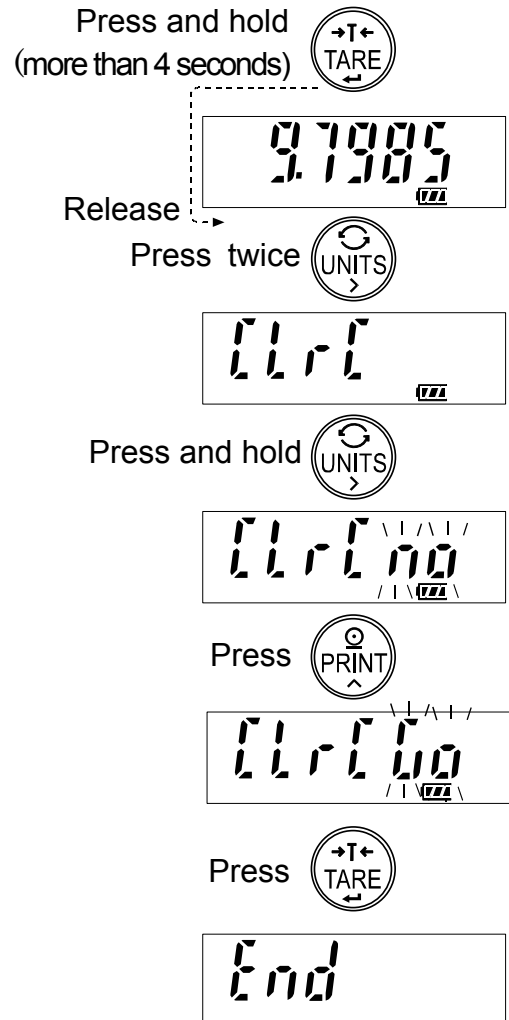

10. FUNCTIONS

The scale has function settings to specify the scale performance. The parameters set in the function settings are maintained even if the power is turned OFF.

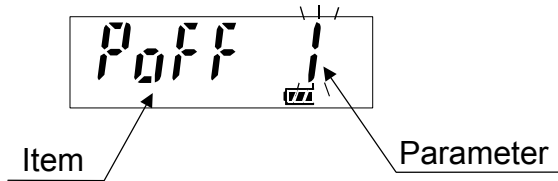

10-1. Setting the parameters

1. Turn the power OFF.
2. Press and hold the **TARE** switch and press the **ON/OFF** switch to turn the power ON. The software version is displayed.
 - ❑ “***” indicates the software version number.
3. Press the **UNITS** switch to display the item.
4. Change the item or parameter using the following switches.
 - UNITS** To display the next item.
 - PRINT** To increase the value of the blinking digit by one (to change the parameter).
 - ❑ When the parameter is changed, the STABLE indicator turns off.
5. Press the **TARE** switch to store the setting value. After “*End*”, the scale returns to the weighing mode.

While holding down, press

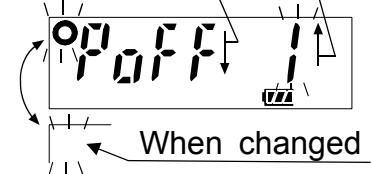
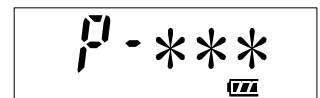

To restore the function settings to the factory setting values

When “*LrFn0*” is displayed, press the **PRINT** switch to change to “*LrF00*”. Then, press the **TARE** switch. The function settings are restored to the factory setting values. After “*End*”, the scale returns to the weighing mode.

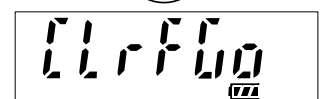
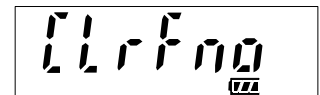

10-2. Function list

Item	Parameter	Description	
Auto power-off function <i>P_{OFF}</i>	0	Auto power-off disabled	Turns the power OFF automatically
	◆ 1	Auto power-off enabled	
Weight display resolution <i>rSE₀</i>	0	Normal (1/3,000)	Changes “d”, minimum display
	◆ 1	High (1/6,000 or 1/7,500)	
Serial interface Baud rate <i>bPS</i>	◆ 0	2400 bps	
	1	4800 bps	
	2	9600 bps	
Serial interface Data output mode <i>Prt</i>	◆ 0	Stream mode Command mode	
	1	Command mode only	
	2	Print switch mode Command mode	
	3	Auto-print mode +/- data Command mode	
	4	Auto-print mode + data Command mode	
Serial interface Response <i>REP</i>	0	No reply except “Q” command	
	◆ 1	Reply to commands	
Comparator mode <i>CP</i>	◆ 0	Comparator disabled	Comparison conditions d = minimum display
	1	Compares all data	
	2	Compares all stable data	
	3	Compares data of > +4d or < -4d	
	4	Compares stable data of > +4d or < -4d	
	5	Compares data of > +5d	
	6	Compares stable data of > +5d	
sStability Response speed <i>Cond</i>	0	Weak / fast response	
	◆ 1	Normal / normal response	
	2	Strong / slow response	
Zero tracking <i>trc</i>	0	Zero tracking function disabled	Tracks the zero drift
	◆ 1	Zero tracking function enabled	
Decimal point <i>dP</i>	◆ 0	Dot (.)	Selects a decimal point type.
	1	Comma (,)	
Initialization <i>CLRF</i>	no	Initialization disabled	Restores the function settings to the factory setting values.
	Go	Initialization enabled	

◆ Factory setting

d = minimum display, the minimum mass that can be weighed
Even the counting mode uses “d” for judgment.

11. OPTIONS

The following options are available for the SC/SE series:

- OP-02 (SCE-02) USB interface
- OP-03 (SCE-03) RS-232C serial interface and Comparator relay output

Note

When an option is installed, the dust-tight and water-tight performance of the scale will be degraded.

For details, refer to the instruction manual for the options.

12. MAINTENANCE

12-1. Notes on maintenance

- Do not disassemble the scale. Contact your local A&D dealer if the scale needs service or repair.
- Use the original packaging for transportation.
- Do not use organic solvents to clean the scale. Use a warm lint free cloth dampened with a mild detergent.
- Calibrate the scale periodically to keep weighing accuracy.

12-2. Error codes

Overload error



Indicates that an object beyond the weighing capacity has been placed on the weighing pan.
Remove the object from the weighing pan.

Underload error



Indicates that the weight sensor receives strong force upward.
Check if the weighing pan is touching anything or if there is anything in the base. There is a possibility that the weight sensor or internal circuit may have a failure.

Unit weight error

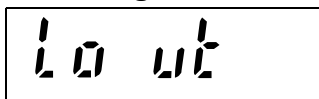

Indicates that the sample weight is too light to set the unit weight in the counting mode.
Increase the number of samples.

Low battery

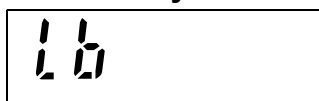

Indicates that the batteries are depleted.
Replace them with new batteries.

Other



The internal circuit may have a failure.
(* indicates an error number.)

- If the error persists or other errors occur, contact your local A&D dealer.

13. SPECIFICATIONS

13-1. Specifications

☐ Materials

	Weighing platform	Weighing pan
SC series:	Stainless steel (SUS304)	Stainless steel (SUS304)
SE series:	Steel	Stainless steel (SUS430)

MODEL	SC-30KAM SE-30KAM	SC-60KAM SE-60KAM	SC-150KAM SE-150KAM	SC-60KAL SE-60KAL	SC-150KAL SE-150KAL
Weighing capacity (kg)	30	60	150	60	150
Minimum display "d" (kg)	0.01	0.02	0.05	0.02	0.05
	0.005 *	0.01 *	0.02 *	0.01 *	0.02 *
Weighing capacity (lb)	66	130	330	130	330
Minimum display "d" (lb)	0.02	0.05	0.1	0.05	0.1
	0.01 *	0.02 *	0.05 *	0.02 *	0.05 *
Weighing capacity (oz)	1050	2100	5200	2100	5200
Minimum display "d" (oz)	0.5	1	2	1	2
	0.2 *	0.5 *	1 *	0.5 *	1 *
Number of samples	5 (can be changed to 10, 20, 50 or 100) pieces				
Maximum count	60,000 pcs	60,000 pcs	75,000 pcs	60,000 pcs	75,000 pcs
Minimum unit weight	0.0005 kg	0.001 kg	0.002 kg	0.001 kg	0.002 kg
Repeatability (Std. deviation)	0.005 kg	0.01 kg	0.02 kg	0.01 kg	0.02 kg
Linearity	±0.01 kg	±0.02 kg	±0.05 kg	±0.02 kg	±0.05 kg
Sensitivity drift	±20 ppm / °C (5°C to 35°C / 41°F to 95°F)				
Display	7 segment LCD (character height 39 mm)				
Display update	10 times per second				
Operating conditions	-10°C to 40°C / 14°F to 104°F, 85% R.H. or less (non-condensing)				
Power supply	Size D (R20P / LR20) batteries x 6				
Battery operating	Approximately 3,600 hours using alkaline batteries				
Weighing pan size	300 x 380 mm / 11.8 x 15.0 in.			390 x 530 mm / 15.4 x 20.9 in.	
Dimensions	SC-KAM: 300(W) x 543(D) x 717(H) mm 11.8(W) x 21.4(D) x 28.2(H) in.			SC-KAL: 390(W) x 688(D) x 717(H) mm	
	SE-KAM: 300(W) x 582(D) x 722(H) mm 11.8(W) x 22.9(D) x 28.4(H) in.			SC-KAL: 15.4(W) x 27.1(D) x 28.2(H) in. SE-KAL: 390(W) x 732(D) x 722(H) mm SE-KAL: 15.4(W) x 28.8(D) x 28.4(H) in.	
Mass (approximately)	SC-KAM: 12 kg SE-KAM: 12 kg			SC-KAL: 16 kg SE-KAL: 16 kg	
Calibration weight (factory setting)	30 kg 60 lb	60 kg 120 lb	150 kg 300 lb	60 kg 120 lb	150 kg 300 lb

* Factory setting

☐ The cable length from the base to the display is approximately 1.5 m.

13-2. External dimensions

● SC-30KAM / SC-60KAM / SC-150KAM

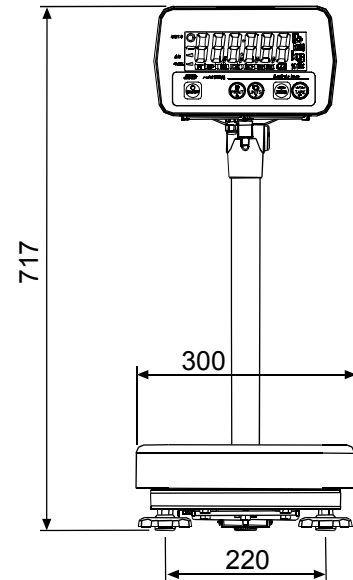
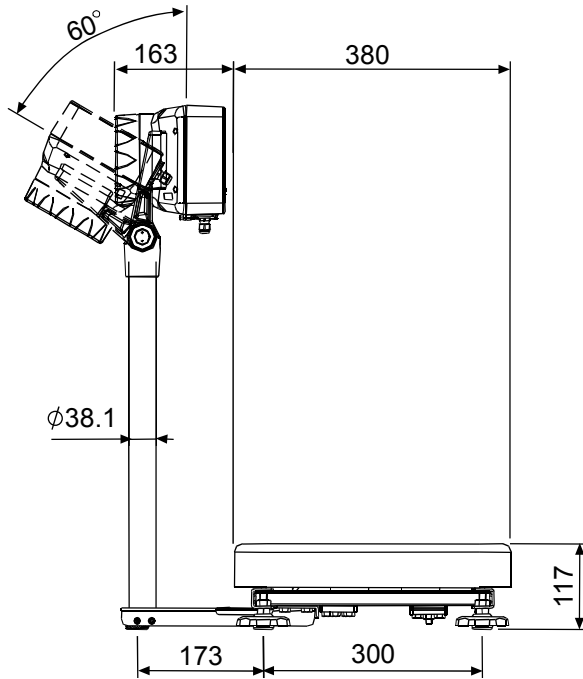

● SC-60KAL / SC-150KAL

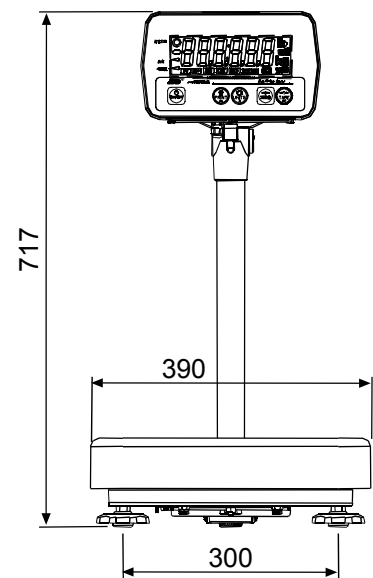
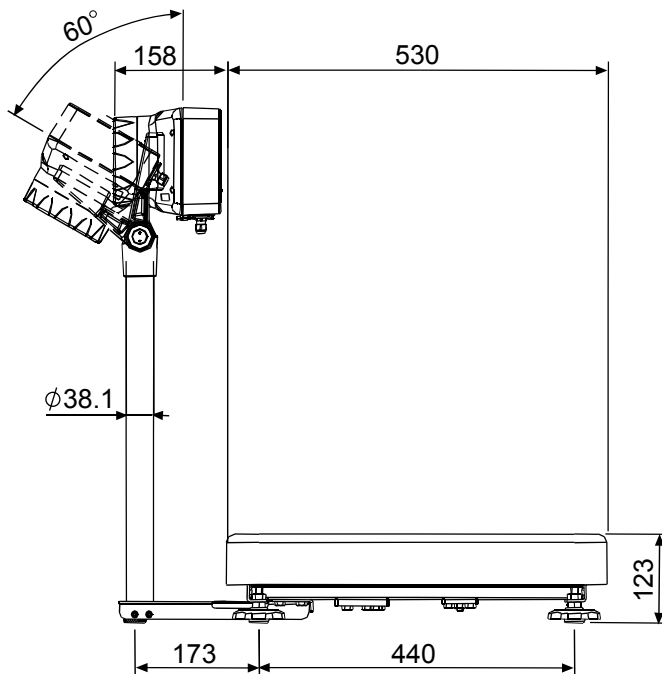

Unit: mm

●SE-30KAM / SE-60KAM / SE-150KAM

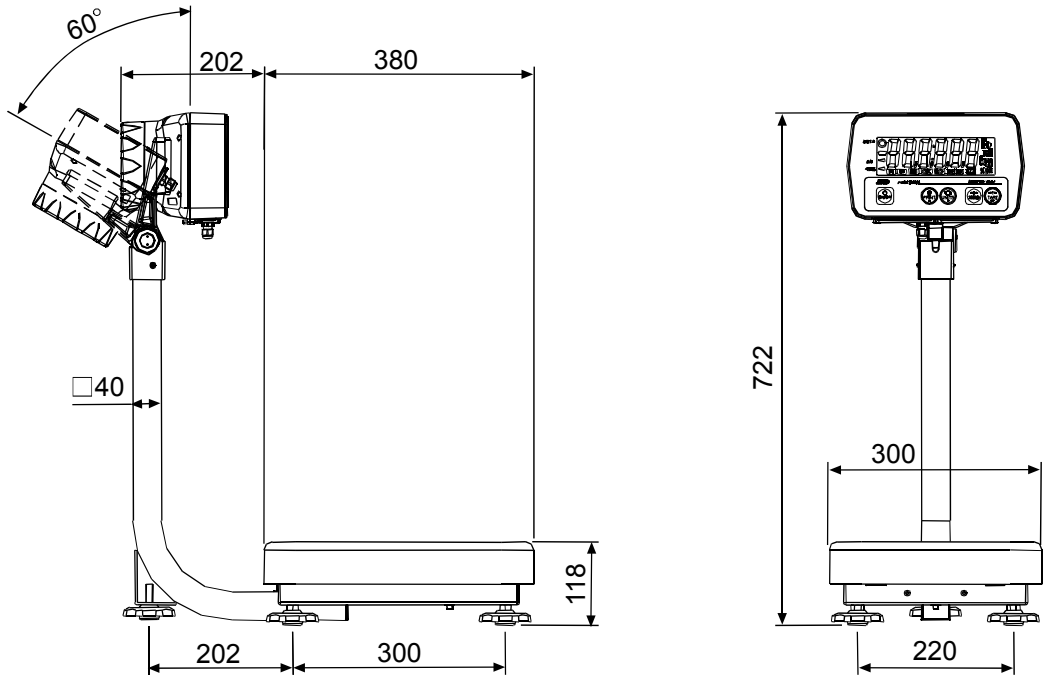

●SE-60KAL / SE-150KAL

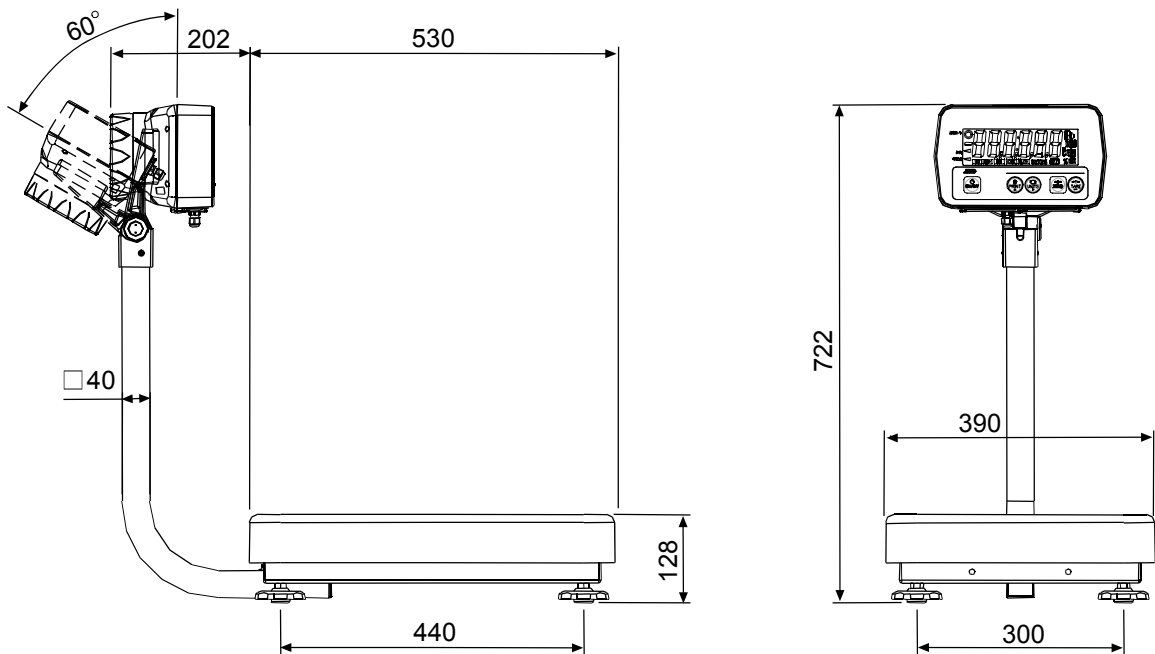

Unit: mm

GRAVITY ACCELERATION MAP

Values of gravity at various locations

Amsterdam	9.813 m/s ²	Manila	9.784 m/s ²
Athens	9.807 m/s ²	Melbourne	9.800 m/s ²
Auckland NZ	9.799 m/s ²	Mexico City	9.779 m/s ²
Bangkok	9.783 m/s ²	Milan	9.806 m/s ²
Birmingham	9.813 m/s ²	New York	9.802 m/s ²
Brussels	9.811 m/s ²	Oslo	9.819 m/s ²
Buenos Aires	9.797 m/s ²	Ottawa	9.806 m/s ²
Calcutta	9.788 m/s ²	Paris	9.809 m/s ²
Cape Town	9.796 m/s ²	Rio de Janeiro	9.788 m/s ²
Chicago	9.803 m/s ²	Rome	9.803 m/s ²
Copenhagen	9.815 m/s ²	San Francisco	9.800 m/s ²
Cyprus	9.797 m/s ²	Singapore	9.781 m/s ²
Djakarta	9.781 m/s ²	Stockholm	9.818 m/s ²
Frankfurt	9.810 m/s ²	Sydney	9.797 m/s ²
Glasgow	9.816 m/s ²	Taichung	9.789 m/s ²
Havana	9.788 m/s ²	Tainan	9.788 m/s ²
Helsinki	9.819 m/s ²	Taipei	9.790 m/s ²
Kuwait	9.793 m/s ²	Tokyo	9.798 m/s ²
Lisbon	9.801 m/s ²	Vancouver, BC	9.809 m/s ²
London (Greenwich)	9.812 m/s ²	Washington DC	9.801 m/s ²
Los Angeles	9.796 m/s ²	Wellington NZ	9.803 m/s ²
Madrid	9.800 m/s ²	Zurich	9.807 m/s ²

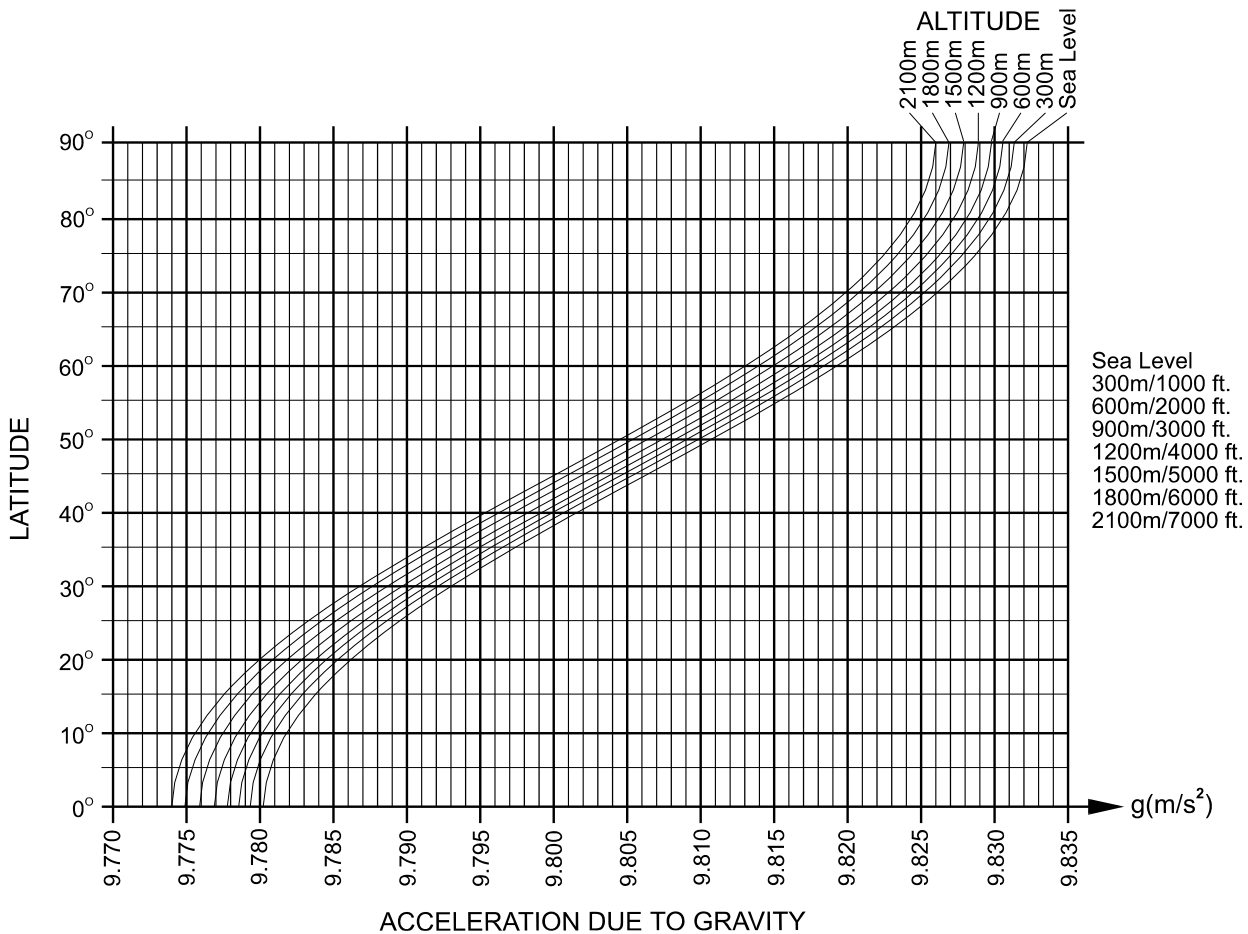

World map

