

AD-4406

OP-03/04/05/07/08/11

WEIGHING INDICATOR

INSTRUCTION MANUAL



WM+PD4000506A

This Manual and Warning Definitions

The warnings described in this manual have the following meanings:

CAUTION	Disregarding the caution could result in loss of important data or damage to the instrument
Note	Provides information useful for the user to operate the instrument.



This is a hazard alert mark.

© 2005 A&D Company Ltd. All rights reserved.

No part of this publication may be reproduced, transmitted, transcribed, or translated into any language in any form by any means without the written permission of A&D Company Ltd.

The contents of this manual and the specifications of the instrument covered by this manual are subject to change for improvement without notice.



Contents

1. Compliance	3
1.1. Compliance with FCC Rules	3
1.2. Compliance with European Directive	3
2. Introduction	4
3. Installation and Precautions	5
3.1. Installation and Precautions	5
3.2. Power Supply	5
3.3. The Load Cell Connections	6
3.4. Adjustment of the Load Cell Output	6
3.5. Verifying Load Cell Output and Input Sensitivity	7
3.6. Installing an Option Board	7
3.7. Attaching the Display Stand (OP-11)	7
4. Description of Panels and Symbols	8
4.1. Front Panel Description	8
4.2. Rear Panel Description	9
4.3. Other Displays and Symbols	9
4.4. Accessories	9
5. Calibration	10
5.1. Items of the Calibration Mode	10
5.2. Calibration Procedure	11
5.2.1. Configuring a Weighing Instrument	11
5.2.2. Specifying the Range and Unit	12
5.2.3. Specifying the Resolution, Decimal Point Position and Format	12
5.2.4. Specifying the Weighing Capacity of the First Range	13
5.2.5. Specifying the Second Range Resolution	13
5.2.6. Specifying the Second Range Capacity	13
5.2.7. To Get Stabilized Data	13
5.2.8. Zero Calibration	14
5.2.9. Span Calibration	14
5.2.10. Exiting the Calibration Mode	15
5.3. Weighing Range Function	16
5.3.1. Setting the Division and Range	17
5.4. Digital Linearization Function	17
5.5. Gravity Compensation Function	18
5.5.1. The Gravity Acceleration Table	19
5.6. Calibration Error Code List	20
6. Functions	21

6.1.	Changing the Function Settings.....	21
6.2.	F-Functions	22
6.3.	CF-Functions	29
7.	Function keys F1 and F2	30
8.	Tare	31
9.	Accumulation	32
9.1.	Preparation and Specification	32
9.2.	Display and Operation	33
10.	Code Memory	35
11.	Comparison	36
11.1.	Weight Check Mode	36
11.1.1.	Condition Formula for Comparison	37
11.1.2.	Setting the Upper/Lower Limit Values	37
11.2.	Setpoint Comparison	39
11.2.1.	Description of Input Parameters and Outputs	39
11.2.2.	Simple Batch	40
11.2.3.	Setting the Parameters of Setpoint Comparison	41
12.	Hold Function.....	42
12.1.	Setting the Hold Functions.....	42
13.	RS-232C Interface (OP-04, OP-05, OP-08).....	44
13.1.	Specifications	44
13.2.	Data Format	45
13.3.	Command Format.....	45
13.3.1.	Commands to Request Data.....	46
13.3.2.	Commands to Control the Indicator	47
13.3.3.	Commands to Set Parameters.....	49
13.3.4.	Commands for Hold Function	49
13.3.5.	Commands to Set Serial Data Output Format (UFC)	50
13.4.	UFC Command	50
14.	RS-422/RS-485, Relay Output (OP-03).....	52
15.	Relay Output & Control Input (OP-05).....	54
16.	4-20 mA Analog Output (OP-07)	55
17.	Current Loop Output (OP-08).....	56
18.	Specifications	58
18.1.	Dimensions.....	59



1. Compliance



1.1. Compliance with FCC Rules

Please note that this equipment generates, uses and can radiate radio frequency energy. This equipment has been tested and has been found to comply with the limits of a Class A computing device pursuant to Subpart J of Part 15 of FCC rules. These rules are designed to provide reasonable protection against interference when this equipment is operated in a commercial environment. If this unit is operated in a residential area it may cause some interference and under these circumstances the user would be required to take, at his own expense, whatever measures are necessary to eliminate the interference.

(FCC = Federal Communications Commission in the U.S.A.)



1.2. Compliance with European Directive



This appliance complies with the statutory EMC (Electromagnetic Compatibility) directive 89/336/EEC and the Low Voltage Directive 73/23/EEC for safety of electrical equipment designed for certain voltages.

Note □ **The displayed value may be adversely affected under extreme electromagnetic influences.**



2. Introduction

- The AD-4406 is a compact weighing indicator that amplifies the signal from a load cell, converts it to digital data and displays it as a mass value.
- This indicator has the following performance:
 - Input sensitivity: 0.2 μ V/division
 - Maximum display: 40000 divisions
 - Refresh rate of the display: 10 times/second approximately
 - Input voltage range: -1 mV to +15 mV
- The following standard functions are available:
 - The HiHi/Hi/OK/Lo/LoLo limit comparison to check a mass value.
 - The setpoint comparison for batching applications.
 - There are four code memories to store the above mentioned data.
 - The accumulation function to totalize these mass values and to count the number of accumulations.
 - The hold function enables weighing a living animal.
 - UFC (Universal Flexi Coms) function to customize the protocol of outputting data using the serial interface.
- The following interfaces are either standard or are available as an option:
 - The RS-232C serial interface to communicate with a computer, printer or remote display. This interface outputs data and can request weight data, enter parameters and control the state of the indicator. (Options: OP-04, OP-05, OP-08)
 - RS-422/485, 3-Relay Outputs (Option: OP-03)
 - RS-232C, 3-Relay Outputs and 3-Control Inputs (Option: OP-05)
 - Analog Output (4-20 mA) (Option: OP-07)
 - RS-232C, Current Loop Output, 3-Relay Outputs and 1-Control Input (Option: OP-08)Only one interface can be installed at a time.
- The calibration function includes the following functions:
 - Setting of the minimum division (weighing interval) and the maximum capacity
 - Zero and span calibration
 - The weighing range function of the multi-interval weighing instrument (scale)
 - Digital linearization function
 - Gravity compensation function



3. Installation and Precautions



3.1. Installation and Precautions

- The AD-4406 weighing indicator is a precision electronic instrument. Handle the indicator carefully.
- The operating temperature is -10°C to +40°C (14°F to 104°F).
- Do not install the indicator in direct sunlight.
- A malfunction or other problems may be caused by an unstable power source including momentary power failure or instantaneous noise. Use a stable power source.
- ⚠ □ When an AC Adapter is used, please confirm that the local voltage and receptacle type are correct for your indicator.
- Use shielded cables for all connections. Connect the cable shields to the shield terminal or case as an earth terminal.
- Earth ground the indicator. Do not join the earth ground line with other electrical power equipment.
- Do not install the indicator in a place where it is apt to be charged with static electricity, or where the relative humidity is lower than 45%RH. Plastic and isolators are apt to be charged with static electricity.



3.2. Power Supply

- When an AC adapter is used
A stable power source must be used; an unstable power source which includes an instantaneous noise component may result in a malfunction.
- When dry batteries are used
Use fresh batteries, preferably alkaline type. Insert batteries into the battery box (use caution in inserting to match the polarity of the batteries), and insert the battery box with the contacts to the inside of the indicator. Push it in and towards the bottom. The battery box will hook onto the edge of the case. Install the cover over the battery box so that it will not fall out.
To remove the battery box, press in and up on the end of the battery box. Slowly release pressure on the battery box while holding it against the top of the battery compartment and the battery box will slide out.
- The AD-1681 rechargeable battery pack can be used in place of the standard battery box.



3.3. The Load Cell Connections

- Connect the load cell wires to the connector (receptacle), at the rear panel, using the accessory load cell plug.
- It is possible to connect a 4 wire cable provided that pins 1-2 and pins 3-4 are shorted, if the distance between the indicator and a load cell is shorter than 5m.
- The output voltage of a load cell is a very sensitive signal. Place the load cell cable away from any noise source.
- It is possible to connect four 350 ohm load cells.

The load cell drive is 5VDC \pm 5% between EXC+ and EXC-, the maximum current 60 mA.

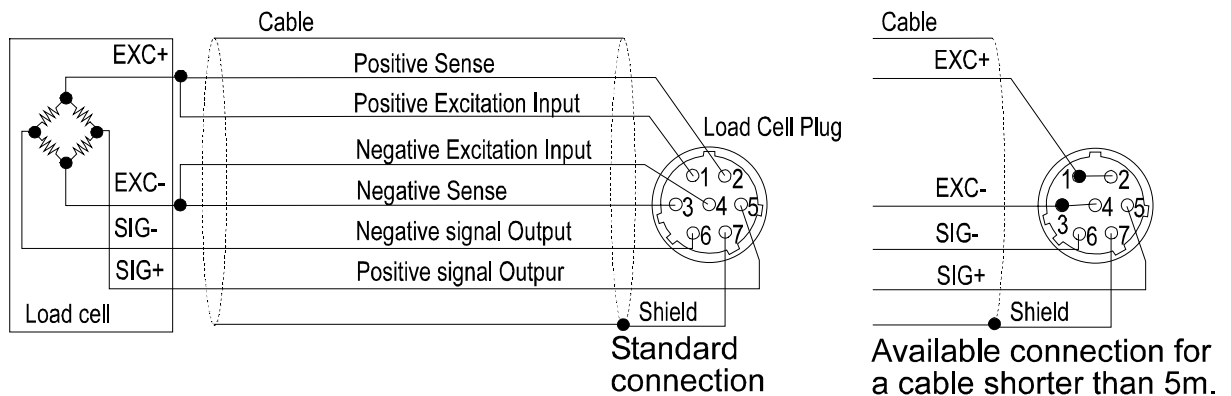

3.4. Adjustment of the Load Cell Output

Caution □ Use a metal film resistor in the range of 50kohm to 500kohm with a good temperature coefficient, when adding a resistor to adjust a load cell output. Use the largest resistance value possible in the range in which zero adjustment is possible. Solder this resistor at a point near the load cell or the indicator.

In Case of Reducing the Output Voltage

When the zero output is too large, add a resistor between EXC+ and SIG-.

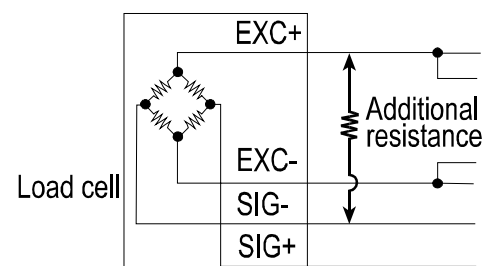

In Case of Adding an Offset Voltage to the Output

When the zero output is too small, add a resistor between EXC+ and SIG+.

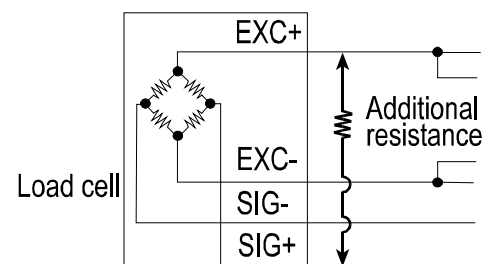



3.5. Verifying Load Cell Output and Input Sensitivity

The input sensitivity of the indicator is 0.2 μV/division or more. Adapt to the following inequality, when you design a weighing instrument using the indicator and load cell(s).

- Caution** □ **A change in input voltage sensitivity is required to cause a one division change in the display. Select as large an input sensitivity voltage as possible so that the weighing interval becomes stable.**
- **Consider the leverage if a lever is used.**

Weighing instrument using one load cell.	$0.2 \leq \frac{E * B * D}{A}$	A: Rated capacity of load cell [kg] B: Rated output [mV/V] D: Weighing interval [kg]
Weighing instrument using multi-load cell	$0.2 \leq \frac{E * B * D}{A * N}$	E: Excitation voltage [mV] N: Number of load cells

Verification Example

Design: Load cell	N=1	$\frac{5000 * 3 * 0.05}{750} = 1 \geq 0.2$. Therefore, regard the instrument as a good design.
Rated capacity	A=750 [kg]	
Rated output	B=3 [mV/V]	
Excitation voltage	E=5000 [mV]	
Weighing interval	D=0.05 [kg]	
Weighing capacity	300 [kg]	



3.6. Installing an Option Board

- Caution** □ **Do not remove any screws without the following step.**

This is the procedure for the data output board (OP-03, OP-04, OP-05, OP-07 and OP-08).

- Step 1 Remove the power cord and other cables from the indicator.
- Step 2 Remove two screws from the rear blank panel.
- Step 3 Remove the rear blank panel.
- Step 4 Insert the option board into both board guides and insert the board. Then the connector between the main board and the option board is connected. If the option board panel will not close completely, retry step 4 to insert the option board correctly.
- Step 5 Secure the option board panel using two screws.



3.7. Attaching the Display Stand (OP-11)

- Caution** □ **Do not remove any screws without the following step.**

- Step 1 Remove the power cord and other cables from the indicator.
- Step 2 Secure the stand to both slide-rails with the bolts provided.



4. Description of Panels and Symbols



4.1. Front Panel Description

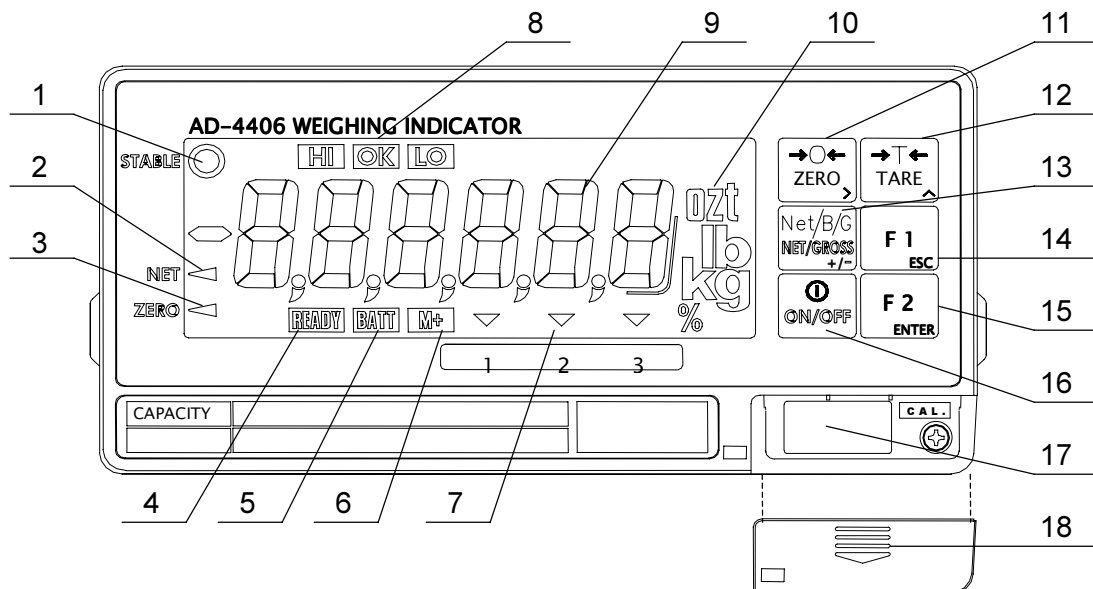

No.	Name	Description
1	STABLE	Indicates when the display is stable.
2	NET	Indicates when the weight is the net weight.
3	ZERO	Indicates when the displayed weight is in the Zero range.
4	READY	Indicates the state of comparison or batching.
5	BATT	Indicates when the battery is low.
6	M+ (Accumulation)	Indicates when there is a result of addition or accumulation.
7	▼ (Triangle mark)	Depending on the function selected, indicates various states.
8	HI/OK/LO	Indicates the results of comparison.
9	Data display	Displays the weight data.
10	Unit of measure	Unit used to weigh
11	ZERO key	The key to zero the current display.
	> key	The key to select the digit while in the setting mode.
12	TARE key	The key to perform tare.
	^ key	The key to select a value while in the setting mode.
13	NET/GROSS key	The key to select net or gross weight in the display.
	+/- key	The key to select + or – of a value.
14	F1 key	The key to execute the setting.
	ESC key	The key to proceed to the next step without storing the data set.
15	F2 key	The key to execute the setting.
	ENTER key	Confirms settings and stores the value.
16	ON/OFF key	Turns the indicator on and off.
17	CAL key	The key to select calibration.
18	CAL cover	Calibration protection cover.

4.2. Rear Panel Description

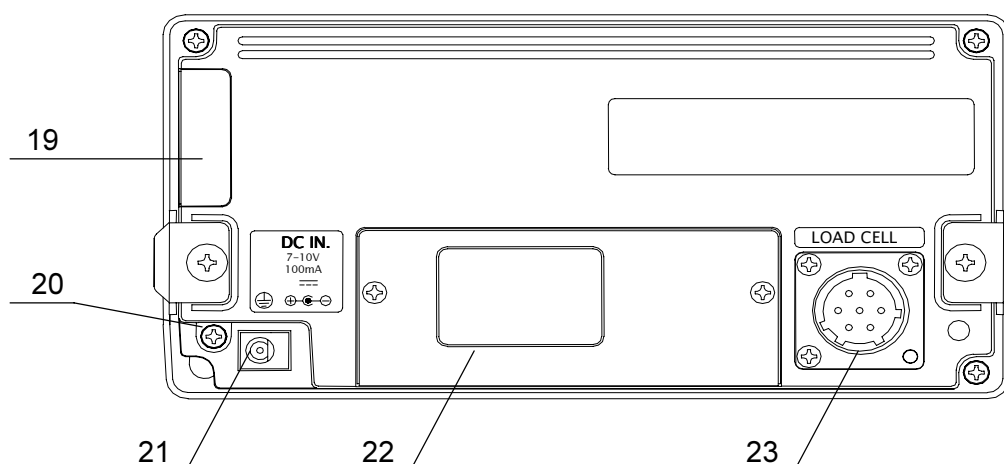

No.	Name	Description
19	Battery cover	Battery compartment cover
20	Grounding terminal	
21	Power jack	Apply 7VDC to 10VDC.
22	Blank panel	Option space (for OP-03, OP-04, OP-05, OP-07 and OP-08)
23	Load cell connector	Connect the accessory load cell plug.

4.3. Other Displays and Symbols

	Standby display
	Zero error when turning the display on. If the ESC key is pressed, the current weight value is displayed.
Blank Decimal point	Overload display. Remove any load from the load cell immediately. It may cause damage to the load cell.
	Battery is weak, change batteries immediately.
	Low Battery, change batteries immediately.
	Example of an error display.

4.4. Accessories

Accessories	Instruction manual	1	
	Load cell plug	1	JM-GCR06A16-7S
	Capacity label	1	
	Annunciator label	1	



5. Calibration

The indicator converts an input voltage from a load cell to a "mass" value and displays it. Calibration is the adjustment function so that the scale (indicator) can weigh correctly.



5.1. Items of the Calibration Mode

There are four items in the calibration function where setting should be done.

How to calibrate: In weighing mode, press the **CAL** key which is located behind the CAL cover at the lower right of the front panel. After **CAL in** is displayed for 2 seconds **CAL 0** will appear. The required items should be selected and displayed with the **ZERO** key, then executed by pressing the **ENTER** key.

* The CAL cover is removed by sliding downward.

Required Items

CALSET

Sets capacity, resolution, decimal point position and display format, weighing range and unit. These items should be set first in order for the indicator to function as a weighing instrument. Set values do not need to be changed again unless the indicator itself is replaced. For details, refer to "5.2.1. Configuring a Weighing Instrument".

CAL 0

Calibrates zero and span. This is required after installation, to get accurate data. For details, refer to "5.2.8. Zero Calibration" and "5.2.9. Span Calibration".

Optional Items (Sub-functions)

Lnr 0

Performs digital linearization. Refer to "5.4. Digital Linearization Function".

G SET

Compensates for acceleration of gravity. Refer to "5.5. Gravity Compensation Function".

Gravity compensation function

Compensates for weighing error between the calibration location and another weighing location using gravity acceleration.

In calibration mode, the keys have functions as follows:

>

When setting values, moves the cursor that is blinking.

^

When setting values, increments the value or displays another setting.

+/-

Displays another setting.

ESC

Proceeds to the next step without changing the set value.

ENTER

Stores the set value and then proceeds to the next step.

CAL Writes all the set data into non-volatile memory and displays **CALoFF** after the **ON/OFF** key is pressed. Note that the **ON/OFF** key does not function alone. Press the **ESC** key while holding the **ON/OFF** key to end the calibration mode when a value is mistakenly set. After **CAnCEL** is displayed, pressing the **ON/OFF** key stops the calibration mode and turns the indicator off.

- Caution**
- ❑ **The maximum display is less than or equal to 40000 divisions. This number is calculated from the maximum capacity divided by the minimum division.**
 - ❑ **Check the accuracy of weighing instrument periodically.**
 - ❑ **Recommended mass, use a mass heavier than 2/3 maximum capacity.**
 - ❑ **Calibrate the scale, if it is moved to another location or the environment has changed.**
 - ❑ **It is not necessary to set the gravity acceleration correction, when calibrating the scale with a calibration mass at the place where the scale is used.**
 - ❑ **Enter the stable weight data while the STABLE mark is displayed. If unstable data is used, it may cause a weighing error. Arrange the condition using the F00 filter function.**
 - ❑ **The span calibration needs the zero calibration data. We recommend that you perform the span calibration immediately after the zero calibration.**
 - ❑ **If you use the dual range function of the multi-interval scale, perform the "Range Function", "Zero Calibration" and "Span Calibration".**



5.2. Calibration Procedure

5.2.1. Configuring a Weighing Instrument

This section explains how to specify the capacity, resolution, decimal point position and display format, weighing range and unit. Perform this procedure when installing the indicator.

When **CALSEt** is displayed, enter this mode by pressing the **ENTER** key.

Specify the range and unit.

Single Range

Specify the resolution, decimal point position and format.



Specify the weighing capacity.

Dual Range

<First range> Specify the resolution, decimal point position and format.



<First range> Specify the weighing range.



<Second range> Specify the resolution.



<Second range> Specify the weighing capacity.

For the range function, refer to “5.3. Weighing Range Function”.

5.2.2. Specifying the Range and Unit

Step1 The range and unit of measure are displayed.

Range display : SinGL : single range
 dUAL : dual range

To change the range function, use the $\square \wedge$ key

Unit display The active unit is displayed. The unit can be changed; such as kg or lb. Calibration is performed using the unit displayed.

Press the $\square >$ key to select a unit.

Press the $\square +/-$ key to select a unit for calibration. The unit for calibration (first unit) is displayed and the alternate unit (second unit) is blinking.

$\square \text{ENTER}$ The key to store the data displayed and proceed to the next step.

$\square \text{ESC}$ The key to proceed to the next step without changing the data.

5.2.3. Specifying the Resolution, Decimal Point Position and Format

Step 2 The resolution will be displayed as $\square \text{d 0.1}$ with decimal point. The indicator displays triangle 1 and the first unit selected at the previous step.

Specify the position of the decimal point with the $\square >$ key. Specify the display format (point or comma) with the $\square +/-$ key. Specify the resolution with the $\square \wedge$ key. The decimal point format for serial data output is selected using the F-function settings.

Press the $\square \text{ENTER}$ key to store the parameters and proceed to the next step.

When pressing the $\square \text{ESC}$ key, regardless of what is displayed, the indicator will proceed to the next step without changing the parameters.

5.2.4. Specifying the Weighing Range of the First Range

Step 3 After displaying **CAP** for 2 seconds, single range or the weighing capacity will be displayed. When dual range is used, **CAP1** is displayed for 2 seconds. Triangle 1 will be displayed. Specify the range or the capacity with the **>** and **^** keys. Press the **ENTER** key to store the parameter and proceed to the next step. When pressing the **ESC** key, regardless of what is displayed, the indicator will proceed to the next step without changing the parameter. The next step is zero calibration in single range or specifying the second range resolution in dual range.

5.2.5. Specifying the Second Range Resolution

Step 4 After displaying **rAnGE2** for 2 seconds, the resolution with decimal point and triangle 2 will be displayed. Specify the second range resolution in the same way as the first range. The decimal point cannot be moved. Specify the second range resolution greater than the first range. Press the **ENTER** key to store the parameter and proceed to the next step. When pressing the **ESC** key, regardless of what is displayed, the indicator will proceed to the next step without changing the parameter.

5.2.6. Specifying the Second Range Capacity

Step 5 After displaying **CAP2** for 2 seconds, the capacity with unit and decimal point will be displayed. Specify the capacity in the same way as the first range. The capacity should be greater than the first range. Press the **ENTER** key to store the parameter and proceed to zero calibration. When pressing the **ESC** key, regardless of what is displayed, the indicator will proceed to the next step without changing the parameter.

5.2.7. To Get Stabilized Data

Step 6 Maintain the following conditions to calibrate the scale (indicator) correctly.

- Maintain a constant temperature, stable power and stable input voltage from the load cell.
- Avoid direct sunshine or near the outlet of an air conditioner.
- Do not install the scale (indicator) where there is a strong magnetic field.

Step 7 Turn the display on and leave it for several minutes.

5.2.8. Zero Calibration

Step 8 Check the **CAL 0** display.

Select a zero calibration method to adjust the zero point.

Weighing input (Normal way)	The adjustment method with nothing on the weighing unit.	To step 9
Digital input	The numerical way to enter a load cell output voltage.	To step 10

Weighing Input

Step 9 Place nothing on the weighing unit. Press the **ENTER** key after the STABLE mark has turned on. The new zero point parameter will be store. Proceed to step11.

ESC key..... To proceed to step 11 without changing the zero point parameter.

Caution Do not press the **ENTER** key while the **STABLE** mark is off (detecting motion). Arrange the condition using the **F00** filter function.

Digital Input

Step10 Pressing the **+/-** key, a stored input voltage parameter of the zero point is displayed in the unit of mV/V. Adjust the input voltage using the following keys.

> key To select a digit.

^ key To select a value.

ENTER key To store the zero point parameter and proceed to the next step.

ESC key..... To proceed to the next step without changing the parameter.

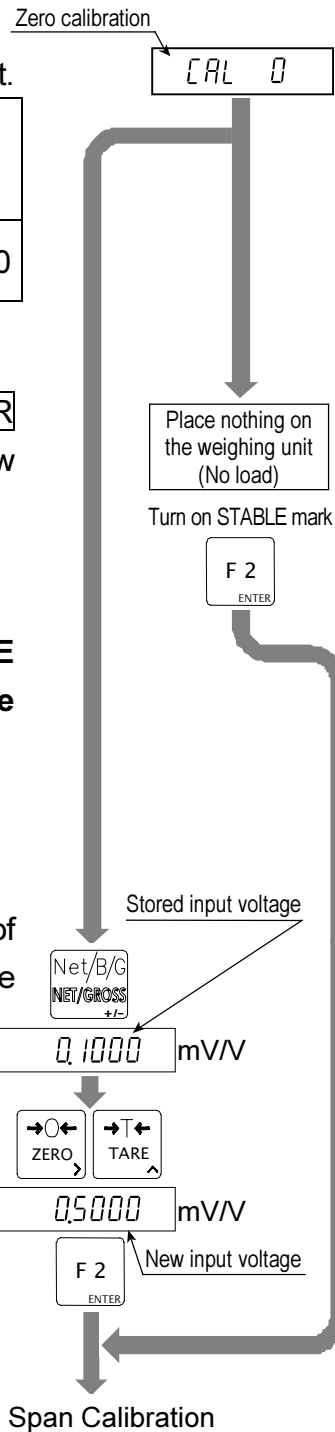

5.2.9. Span Calibration

Step11 Check the capacity display after **CAL F** is displayed for 2 seconds.

Select a span calibration method to adjust the capacity.

Weighing a mass less than the maximum capacity	The method to weigh a mass less than the maximum capacity.	To step 12
Weighing a maximum capacity mass	The method to weigh a mass equivalent to the maximum capacity.	To step 14
Digital input	The numerical way to enter a load cell output voltage.	To step 16

Weighing a Mass less than the Maximum Capacity

- Step12 Set a mass value using the following keys.
 > key To select a digit.
 ^ key To select a value.
- Step13 Place a mass equivalent to the displayed value on the weighing unit. Proceed to step 15.

Weighing a Maximum Capacity Mass

- Step14 Place a mass equivalent to the maximum capacity on the weighing unit.
- Step15 Press the **ENTER** key after the STABLE mark turns on. Proceed to step 17.
ESC key..... To proceed to step 17 without changing the span parameter.

Caution Do not press the **ENTER key while the STABLE mark is off (detecting motion). Arrange the condition using the F00 filter function.**

Digital Input

- Step16 Pressing the +/- key, a stored input voltage parameter of the span is displayed in the unit of mV/V. Adjust the input voltage using the following keys.
 > key To select a digit.
 ^ key To select a value.
ENTER key To store the span parameter and proceed to step 17.
ESC key..... To proceed to step 17 without changing the span parameter.

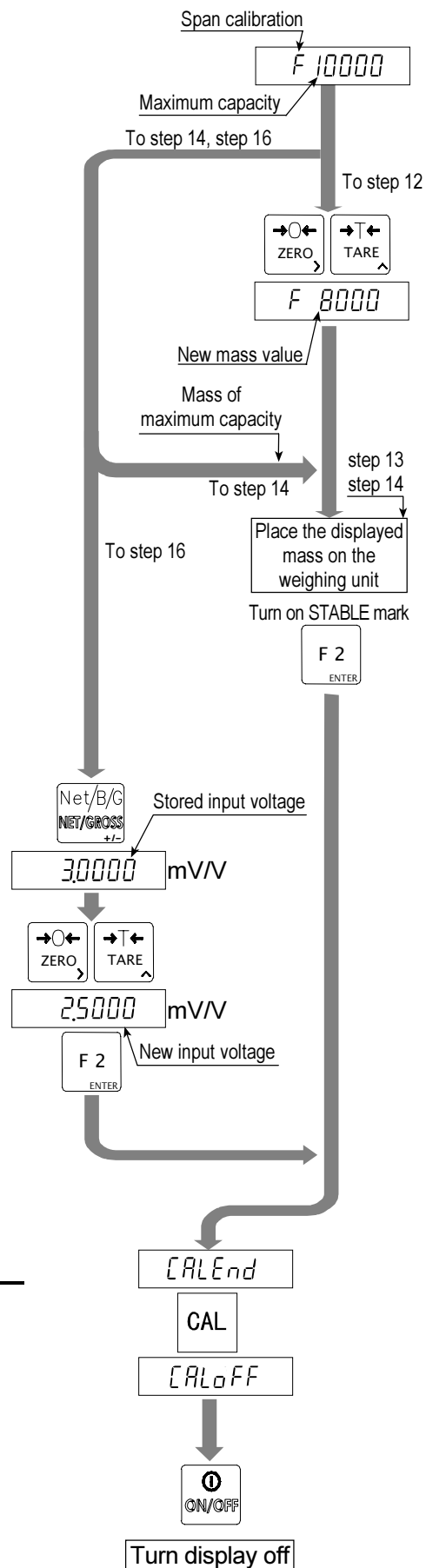

5.2.10. Exiting the Calibration Mode

- Step17 Check the **CALEnd** display.
 Use the following keys.
CAL key..... To store the parameters and display **CALoFF** . Proceed to the next step.
ESC key To store the parameters temporarily. Proceed to the **CAL 0** display.

Press and hold the **ON/OFF** key and press the **ESC** key.

No parameters are changed,

CAnCEL is displayed and the calibration mode is finished.

Step18 Press the **ON/OFF** key to turn the display off.



5.3. Weighing Range Function

The weighing range function can select "single range" or "dual range". Specify each weighing interval (division) for the multi-interval instrument. Each weighing interval is displayed according to a net value or gross value.

Note □ **When single range is used, performing this function is not required.**

Example 1 The gross display.

Specified parameters:

First range Range = 50.00 kg, division 0.02 kg

Second range Range = 100.00 kg (maximum capacity), division 0.1 kg

Display

0 kg to 50 kg : The first range, division 0.02 kg.

50 kg to 100 kg : The second range, division 0.1 kg.

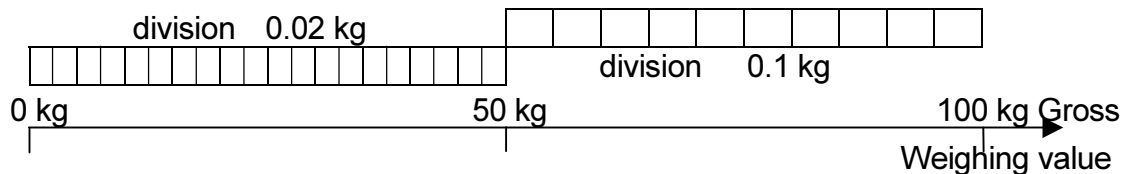

Example 2 The net display using a 40kg tare value.

Specified parameters: The same parameters as example 1.

Display

-40 kg to 50 kg : The first range, division 0.02 kg.

50 kg to 60 kg : The second range, division 0.1 kg.

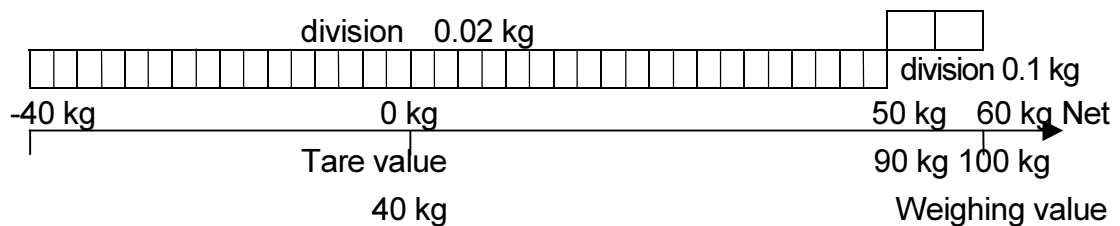

5.3.1. Setting the Division and Range

Consider the following rules to design the weighing range.

Rule 1 Select the division and range of each weighing range so as to fit the following inequality.

The first range < the second range

The division of the next weighing range is automatically set larger than the division of the lower weighing range.

Rule 2 When setting the dual range, the upper limit value of the second range becomes the maximum capacity.

Rule 3 Select a resolution smaller than 40000. The resolution is a value obtained by dividing the maximum capacity by the minimum division of the first range.



5.4. Digital Linearization Function

Even if the zero and span calibration have been completed, there may still remain a linearity deviation caused by the performance of the weighing unit. The digital linearization function can rectify or reduce the linearity deviation using weighing points during the zero and capacity setting. Up to three weighing points can be specified.

- Caution**
- This function does not improve repeatability or hysteresis.
 - Use the mass on the condition that $Lnr\ 1 < Lnr\ 2 < Lnr\ 3$.
 - Do not press the **ENTER** key while the **STABLE** mark is off.

Step 1 Check the **CAL 0** display. Press the **>** key to display **Lnr 0**.

Step 2 Enter the zero point. Refer to "5.2.8. Zero Calibration".

Step 3 The value of the middle point is displayed after indicating **Lnr x**. x is 1, 2 or 3. The ▼ mark of the same number (x) is displayed along with the value.

Step 4 Select a middle point.

□ If you want to cancel the current procedure, press the **ESC** key to finish this function. Proceed to step 7 and the other points are cleared (canceled).

□ Select a middle point value using the following keys. Proceed to step 5.

> keyTo select a digit.

^ key.....To select a value.

Step 5 Place a mass equivalent to the displayed value on the weighing unit. Press the **ENTER** key after the **STABLE** mark has turned on. Proceed to step 6.

Step 6 If you include a 2nd and 3rd middle point, repeat steps 3, 4, 5 for each. If you finish this function, proceed to step 7.

Step 7 Perform step 11 of "5.2.9. Span Calibration" immediately.



5.5. Gravity Compensation Function

- If the scale is used at the calibration location, it is not necessary to perform this function.
- If there is a difference of gravity acceleration between the installed location and calibration location, it may cause a weighing error. This function specifies these gravity accelerations and corrects the span error.

Note

- **The decimal point is not displayed in the function. Example: $\boxed{9798} = 9.798 \text{ m/s}^2$**
- **When span calibration is executed, the gravity acceleration correction will be cleared and two gravity acceleration values will return to the factory settings.**

Step 1 At the $\boxed{\text{CAL } 0}$ display, press the $\boxed{>}$ key until $\boxed{\text{G SEt}}$ is displayed and press the $\boxed{\text{ENTER}}$ key to enter the gravity compensation function.

If you want to cancel the current procedure, press and hold the $\boxed{\text{ON/OFF}}$ key and press the $\boxed{\text{ESC}}$ key. Then, no parameters are changed and the calibration mode is finished. Press the $\boxed{\text{ON/OFF}}$ key to turn the display off after displaying $\boxed{\text{CAnCEL}}$.

Step 2 The parameter is displayed with triangle 1. Enter the gravity acceleration of the calibration location. The parameter xxxx is the gravity acceleration.

$\boxed{>}$ key To select a digit.

$\boxed{\wedge}$ key To select a value.

$\boxed{\text{ENTER}}$ key .. To store the new gravity acceleration and proceed to step 3.

$\boxed{\text{ESC}}$ key To return to $\boxed{\text{G SEt}}$ without changing the value.

Step 3 The parameter is displayed with triangle 2. Enter the gravity acceleration of the installed location. The parameter xxxx is the gravity acceleration.

$\boxed{>}$ key To select a digit.

$\boxed{\wedge}$ key To select a value.

$\boxed{\text{ENTER}}$ key . To store the new gravity acceleration and proceed to step 4.

$\boxed{\text{ESC}}$ key To return to step 2 without changing the value.

Step 4 Now $\boxed{\text{G xxxx}}$ is displayed. Press the $\boxed{\text{CAL}}$ key to store the parameters. $\boxed{\text{CALoFF}}$ is displayed. Proceed to step 5.

Step 5 Press the $\boxed{\text{ON/OFF}}$ key to turn the display off.

5.5.1. The Gravity Acceleration Table

Amsterdam	9.813 m/s ²	Manila	9.784 m/s ²
Athens	9.800 m/s ²	Melbourne	9.800 m/s ²
Auckland NZ	9.799 m/s ²	Mexico City	9.779 m/s ²
Bangkok	9.783 m/s ²	Milan	9.806 m/s ²
Birmingham	9.813 m/s ²	New York	9.802 m/s ²
Brussels	9.811 m/s ²	Oslo	9.819 m/s ²
Buenos Aires	9.797 m/s ²	Ottawa	9.806 m/s ²
Calcutta	9.788 m/s ²	Paris	9.809 m/s ²
Chicago	9.803 m/s ²	Rio de Janeiro	9.788 m/s ²
Copenhagen	9.815 m/s ²	Rome	9.803 m/s ²
Cyprus	9.797 m/s ²	San Francisco	9.800 m/s ²
Djakarta	9.781 m/s ²	Singapore	9.781 m/s ²
Frankfurt	9.810 m/s ²	Stockholm	9.818 m/s ²
Glasgow	9.816 m/s ²	Sydney	9.797 m/s ²
Havana	9.788 m/s ²	Tainan	9.788 m/s ²
Helsinki	9.819 m/s ²	Taipei	9.790 m/s ²
Kuwait	9.793 m/s ²	Tokyo	9.798 m/s ²
Lisbon	9.801 m/s ²	Vancouver, BC	9.809 m/s ²
London (Greenwich)	9.812 m/s ²	Washington DC	9.801 m/s ²
Los Angeles	9.796 m/s ²	Wellington NZ	9.803 m/s ²
Madrid	9.800 m/s ²	Zurich	9.807 m/s ²

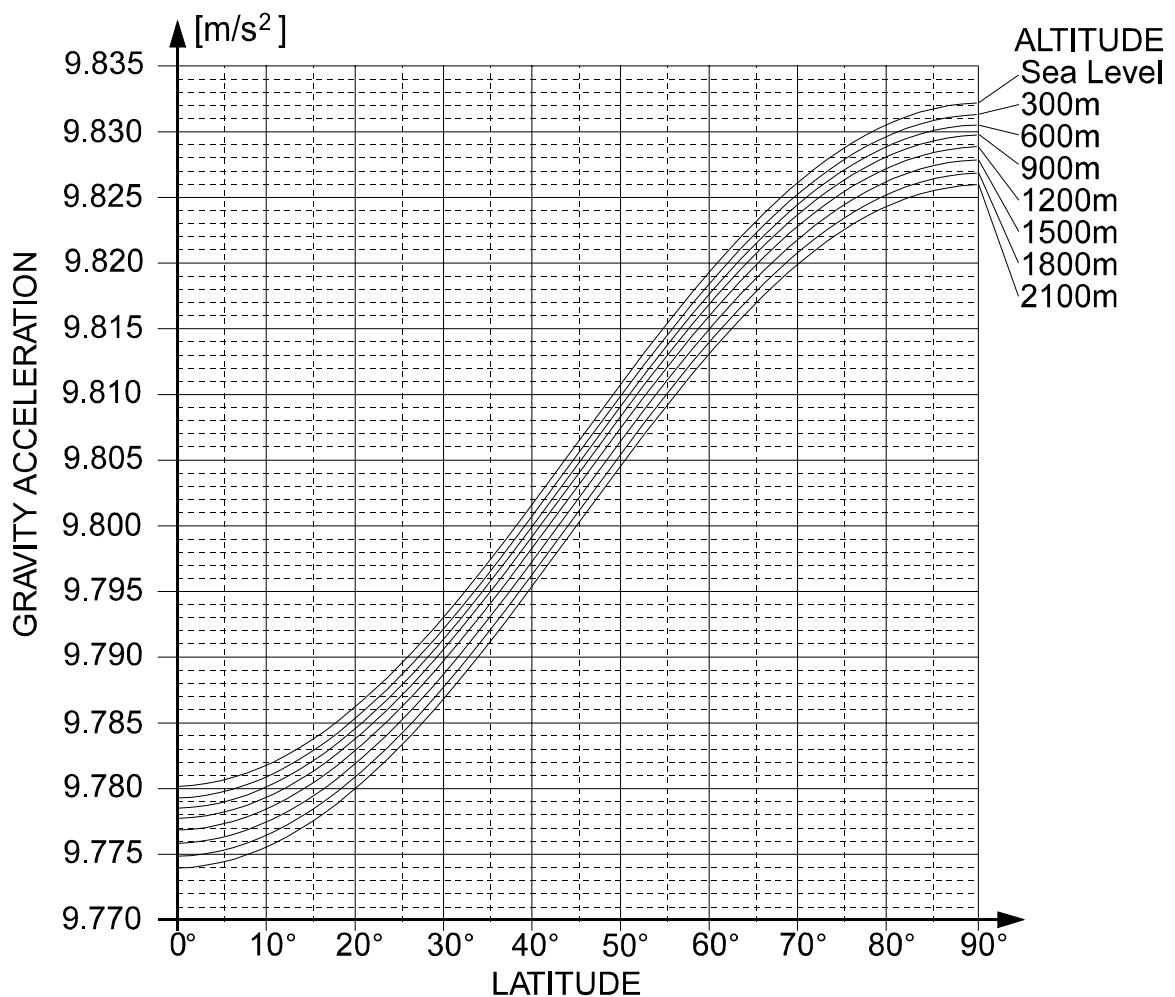



5.6. Calibration Error Code List

Exiting from a Calibration Error

ESC key To return to the point where an error occurred. Retry the operation.

ESC key while pressing the **ON/OFF** key.

No parameters are changed, **CAnCEL** is displayed and the calibration mode is finished.

Error Code List

If an error has occurred during calibration mode, the following code is displayed.

Error code	Description
Err 0	With a multi-interval scale. The last division is set to maximum (d-50). Therefore the next division can not be entered.
Err 1	The resolution exceeds 40000. (Resolution = maximum capacity/ minimum division) Reduce the maximum capacity or increase the minimum division.
Err 2 Err 3	The load cell output is too large or too small at zero calibration. Check the weighing unit and load cell. Refer to "3.5.Verifying Load Cell Output and Input Sensitivity".
Err 4	Measuring calibration mass (or entering digital input), the value exceeded the maximum capacity. Reduce calibration mass (or digital input).
Err 5	The selected calibration mass is smaller than the minimum division.
Err 6	The new input sensitivity is less than 0.2 μ V/division. Increase the input sensitivity. Refer to "3.5.Verifying Load Cell Output and Input Sensitivity".
Err 7	Placing a mass on the weighing unit, the load cell output becomes a negative value. Check the load cell cable connections and the direction of load cell mounting.
Err 8	The load cell output exceeds the input range before the maximum capacity. Adjust the zero balance referring to "3.5.Verifying Load Cell Output and Input Sensitivity". Replace with a load cell designed for a smaller output. Reduce the maximum capacity.
Err 9	The weighed value is out of the input range at zero calibration or span calibration. Check the weighing unit and cables.
Err 12	The previous weighing range is larger than next weighing range.
Err 13	An incorrect mass is selected at the digital linearization function. Select a mass of the following relation. $\text{Inr } 1 < \text{Inr } 2 < \text{Inr } 3$.
G Err	An unacceptable value was selected in the gravity acceleration function.



6. Functions

There are two parameter lists, one for the F-functions and one for CF-functions. These functions control the indicator. The parameters of each function are stored in non-volatile memory, and are not lost even if power is turned off.

F-functions: These parameters can always be changed and are used for internal settings.

CF-functions: If you accept a certificated approval of the weighing instrument, the CAL cover must be sealed. Therefore, accepting this approval, the parameters of the CF-function can not be changed.



6.1. Changing the Function Settings

To enter the function settings, do either of the following.

- 1 When the display is off, press the **ON/OFF** key while pressing the **+/-** key.
- 2 When in weighing mode, press both the **F1** and **F2** keys at the same time.

When you are in the function setting, **F00** will be displayed.

Operating Item

Step 1 Select an item using the following keys.

- >** key To select a digit.
- ^** key To select a value.
- ENTER** key . To display a parameter of the selected item.
Proceed to step 2.
- ESC** key To end setting the functions and enter the weighing mode.
- CAL** key To exchange F-functions and CF-functions.

Operating Parameter

Step 2 Select a parameter using the following keys.

- >** key To select a digit or a sub item (Type 2 or Type 3).
- ^** key To select a value or condition
- ENTER** key . To store a parameter and proceed to step 1.
- ESC** key To proceed to step 1 without changing the parameter.

Display off

Press the **ON/OFF** key to turn the display off. This stores the changes.

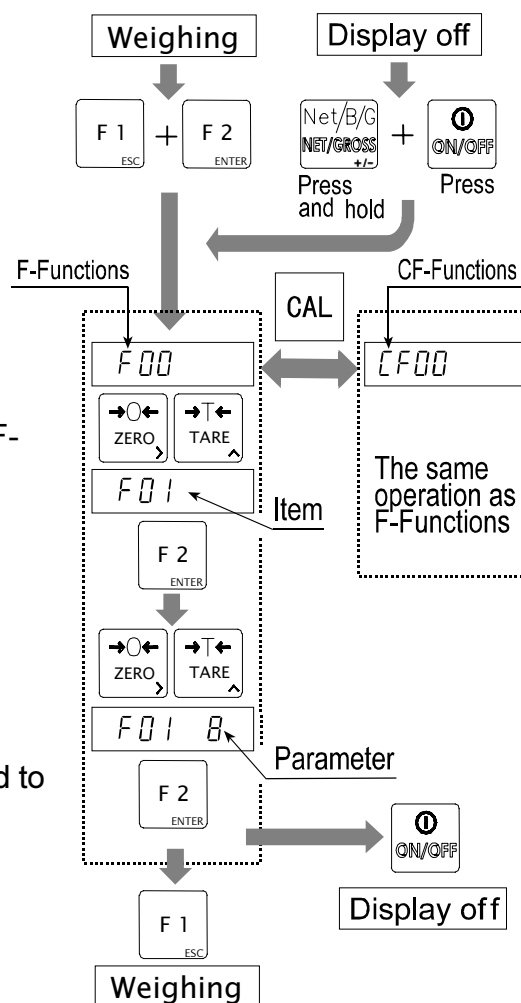



6.2. F-Functions

Weighing Conditions (Digital filter, Zero trucking and Stability)

Item	Parameter	Description
F00 Filter Motion / Averaging time	0	2 d/ 1.6s
	1	4 d/ 1.6s
	2	8 d/ 1.6s
	3	16 d/ 1.6s
	4	32 d/ 1.6s
	5	64 d/ 1.6s
	6	128 d/ 1.6s
	7	2 d/ 3.2s
	* 8	4 d/ 3.2s
	9	8 d/ 3.2s
	10	16 d/ 3.2s
	11	32 d/ 3.2s
	12	64 d/ 3.2s
	13	128 d/ 3.2s
F01 Zero tracking	0	OFF
	1	0.5 d/ 1s
	2	1.0 d/ 1s
	3	1.5 d/ 1s
	4	2.0 d/ 1s
	5	2.5 d/ 1s
	6	0.5 d/ 2s
	7	1.0 d/ 2s
	* 8	1.5 d/ 2s
	9	2.0 d/ 2s
	10	2.5 d/ 2s
F02 STABLE mark (Motion detection) condition	0	No motion detection
	1	0.5 d/ 0.5s
	2	1.0 d/ 0.5s
	3	2.0 d/ 0.5s
	4	3.0 d/ 0.5s
	5	4.0 d/ 0.5s
	6	0.5 d/ 1s
	7	1.0 d/ 1s
	* 8	2.0 d/ 1s
	9	3.0 d/ 1s
	10	4.0 d/ 1s
F03 Auto print/Auto accumulation timing	0	1 (STABLE on)
	1	Twice in succession
	* 2	Three times
	3	Four times

d: division (weighing interval) of the first range s: second *: Initial settings

Display and Other General Settings

Item	Parameter	Description	
F04 Display update rate	* 0	5 times/s	The selection for the unstable condition.
	1	10 times/s	
F05 [Type2] Buzzer	1 x	Key click (ON/OFF)	Left: Item, select using the key Right: parameter, select using the key 0: no sound, 1: continuous 2: 4 times/s, 3: 2 times/s 4: 1 time/s, 5: 1 time/2s Initial value is 11, others x0
	2 x	LoLo /Zero band	
	3 x	LO	
	4 x	OK	
	5 x	HI	
	6 x	HiHi/Batch finish/Full	
F06 Device ID (Address)	00 to 99	Command address or Device ID	Initial setting is 00.
F07 Auto power off	* 0	Not automatically off	Stable and not using for 5 min., automatically power off.
	1	5 minutes	

s: second.

*: Initial settings.

Key Switch

Item	Parameter	Description														
F10 [Type2] F1 key function	x 0	No function	Left: Priority, select using the key Right: Function (listed), select using the key The first priority is operated by pressing and releasing the key quickly, pressing the key for more than two seconds, lower priority functions are displayed sequentially. Initial value is 13, others x0													
	x 1	Serial data output 1														
	x 2	Serial data output 2														
	x 3	Accumulation (M+)														
	x 4	"totAL" display														
	x 5	Setting setpoint														
	x 6	Start comparator, batch														
	x 7	Stop comparator, batch														
	x 8	Stop buzzer sound														
	x 9	Unit change														
	x A	Hold start / release														
F11 [Type2] F2 key function		same as F10	Initial value is 11, others x0													
F12 [Type2] Disabling keys	2 0	A key is selected by the left parameter														
	<table border="1" style="margin-left: 40px;"> <tr> <td>* </td> <td>enable</td> <td rowspan="2"> key</td> </tr> <tr> <td>!</td> <td>disable</td> </tr> </table>		*	enable	key	!	disable	A key condition is selected by the right parameter:								
*	enable	key														
!	disable															
		<table border="1" style="margin-left: 40px;"> <tr> <td>1</td> <td>ZERO key</td> <td rowspan="6"> key</td> </tr> <tr> <td>2</td> <td>TARE key</td> </tr> <tr> <td>3</td> <td>NET/GROSS key</td> </tr> <tr> <td>4</td> <td>F1 key</td> </tr> <tr> <td>5</td> <td>F2 key</td> </tr> <tr> <td>6</td> <td>ON/OFF key</td> </tr> </table>	1	ZERO key	key	2	TARE key	3	NET/GROSS key	4	F1 key	5	F2 key	6	ON/OFF key	When specifying 1 at the right parameter, this key does not work. Use the function to avoid unintentional operation of 6 keys in the table at the left.
1	ZERO key	key														
2	TARE key															
3	NET/GROSS key															
4	F1 key															
5	F2 key															
6	ON/OFF key															



*: Initial settings

External Input

Item	Parameter	Description
F13 EXT1 Function selection of external input	* 0	Not used (No function)
	1	ZERO key
	2	TARE key
	3	NET/GROSS key
	4	OFF key (Not ON)
	5	F2 key
	6	F1 key
	7	Serial data output (Format 1)
	8	Serial data output (Format 2)
	9	Accumulation (M+)
	10	Start batching
	11	Stop batching
	12	Over signal. Gross over and displayed data are output.
	13	Net weight display when shorting the terminal.
	14	Accumulated data display when shorting the terminal.
	15	Execute comparison when shorting the terminal
	16	Display by the second unit when shorting the terminal.
	17	All keys are enabled when shorting the terminal.
	18	Inhibit memory code reading when shorting the terminal.
	19	Start averaging to hold
20	Release holding data	
F14 EXT2	0 - 17, 19 and 20	Same as F-13
	18	Memory code (BCD 1)
F15 EXT3	0 - 17, 19 and 20	Same as F-13
	18	Memory code (BCD 2)

*: Initial settings

Accumulation

Item	Parameter	Description
F20 [Type2] Accumulation Mode	10/11	Acc. no (0) / Exec (1)
	20/21	Manual (0) / Auto (1)
	30/31	+ only (0) / +/- (1)
	40/41	OK only / All data (1)
		Left: Sub item, select using the  key Right: Setting, select using the  key Initial settings: 10,21,31,41
F21 Inhibit region for accumulation	0	Add data anytime
	* 1	Above ± 5 d
	2	Above ± 10 d
	3	Above ± 20 d
	4	Above ± 50 d
		The selection of the inhibit region for accumulation. Do not set F21=0 when Auto accumulation (F20:21)

d: division (weighing interval) of the first range *: Initial settings

Comparator

Item	Parameter	Description	
F22 Comparator function	* 0	Not used	
	1	Upper/lower limit comparison (2 Limits setting)	
	2	Upper/lower limit comparison (Target and allowance)	
	3	Upper/lower limit comparison (Target and % allowance)	
	4	HH/Hi/OK/Lo/LL comparison (4 Limits setting)	
	5	HH/Hi/OK/Lo/LL comparison (Target and allowance)	
	6	HH/Hi/OK/Lo/LL comparison (Target and % allowance)	
	7	Check weighing 1	
	8	Check weighing 2	
	9	Check weighing 3	
	10	Simple batch 1	
	11	Simple batch 2	
12	Simple batch 3 (Loss in weight)		
F23 (F22=1-6) [Type2] Validation of comparison	10/11	Includes zero band (1)	Initial settings are 11,21,31,40
	20/21	Includes minus (1)	
	30/31	Stable (0) /All time (1)	
	40/41	All time (0) /Start, stop (1)	
F23 (F22=10-12) [Type2] Sub function for batch weighing	10/11	Tare when start (1)	Initial settings are 11,21,31,40
	20/21	Stop after Full by key (0) /Auto (1)	
	30/31	Over/Under judgment: after dribble flow (0) / Batch finish (1)	
	40/41	Start with press and hold TARE (1)	
F24 Relay output selection	* 0	Over	Effective when F22=7,9,10,12
	1	Under	
	2	Finish/Full (F22=9,10,12)	
F25 Batch finish output time	0.0 to 9.9	Relay on time by 0.1second step (0.0:continuous to zero band)	Initial setting is 0.0
F26 Zero band	-999999 to 999999		Initial setting is 0

*: Initial settings

Hold Function

Item	Parameter	Description	
F27 Hold mode	* 0	No hold	
	1	Manual hold	
	2	Auto hold	
	3	Manual/auto hold	
F28 Averaging time	0.0 to 9.9	Averaging time by 0.1second step (0.0:hold at averaging start)	Initial setting is 0.0

*: Initial settings

Data Output

Item	Parameter	Description	
F30 Data output	* 0	No data output	
	1	Analog output	Set F31, 32, 33
	2	Serial output	RS-232C,
	3	Serial output (Zero suppressing)	RS-422/485

*: Initial settings (In case of installing RS-232C, F30 is set to 2.)

Analog Output

Item	Parameter	Description	
F31 Output data	* 0	Displayed data	
	1	Gross data	
	2	Net data	
F32 Weight value at 4 mA output	-999999 to 999999 (Initial setting is 0)		Polarity is changed by pressing the <input type="button" value="+/-"/> key.
F33 Weight value at 20 mA output	-999999 to 999999 (Initial setting is 10000)		

*: Initial settings

Serial Data Format

Item	Parameter	Description	
F34 Serial data format 1 Initial value 19J,2EJ,3A,4F,E50	x 0	Terminator	
	x 1	Device ID (selected at F06)	
	x 2	Code number	
	x 3	Data number	
	x 4	Result of comparison	
	x 5	(Reserved)	
	x 6	(Reserved)	
	x 7	Accumulated value	
F35 Serial data format 2 Initial value 17,2F,E30	x 8	Accumulation count	
	x 9	Stable/Over	
	x A	Displayed weight	
	x B	Gross weight	
	x C	Net weight	
	x D	Tare weight	
	x E	Weight type (G / N / T, refer to CF06)	
x F	Weight unit (refer to CF07)		
		100,10:order of output (1-999) Select with the <input type="button" value=">"/> key. 1: output data Select with the <input type="button" value="^"/> key. "Exxx" indicates the end of data to output. Press <input type="button" value="NET/GROSS"/> to expand or shorten the output data length.	

1 "J" (right hand of the figure) of the display indicates that the comma (F46=0, semi-colon for F46=1) is output after the data. To turn this mark on and off, press the and keys at the same time.

Output of initial settings of F34 (19J, 2EJ, 3A, 4F, 50) is like "ST,GR,12345.6kg".

2 The data number (parameter 3) increments automatically with each serial data output from 1 to 99999 (the next of 99999 is 1). The starting number can be set by the keys (F2 + NET/GROSS).

Current Loop Output

Item	Parameter	Description
F36 Output data	* 0	Displayed data
	1	Gross data
	2	Net data
	3	Tare data
	4	Gross data/Net data/Tare data
F37 Output mode	0	Stream mode
	1	Manual mode
	2	Auto print mode (+)
	3	Auto print mode (+/-)
	4	When accumulation, automatically output
	* 5	No output
F38 Delay for continual data	* 0	No delay
	1	2.0 seconds (F36=4, except F37=0)
F39 Baud rate	0	600 bps
	1	1200 bps
	* 2	2400 bps

bps: bit per second

*: Initial settings

Serial Interface

Item	Parameter	Description
F40 Output mode	* 0	Stream mode, command is not acceptable
	1	Manual mode, command is effective
	2	Auto print mode (+) , command is effective
	3	Auto print mode (+/-), command is effective
	4	When accumulation, automatically output
	5	Command mode
F41 Accumulated data output at accumulated data display	0	No output
	* 1	Manual, Fixed format
	2	Auto, Fixed format
	3	Manual, Format 1 (F34)
	4	Auto, Format 1 (F34)
	5	Manual, Format 2 (F35)
F42 Delay for continual data	* 0	No delay
	1	0.5 second
	2	1.0 second
	3	1.5 seconds
	4	2.0 seconds
F43 Command address	* 0	Not used
	1	Used (Address selected at F06)
F44 Time out	* 0	Approx. 1 second
	1	No limitation
F45 Terminator	* 0	CR, LF
	1	CR

*: Initial settings

Serial Interface (continued)

Item	Parameter	Description
F46 DP / Delimiter	* 0	DP: point (.) / Delimiter: comma (,)
	1	DP: comma (,) / Delimiter: semicolon (;)
F47 Baud rate	0	600 bps
	1	1200 bps
	* 2	2400 bps
	3	4800 bps
	4	9600 bps
F48 Data bits, parity	* 0	Data 7 bits, Even parity
	1	Data 7 bits, Odd parity
	2	Data 8 bits, Non parity

*: Initial settings

bps: bit per second

Description of "Stream Mode"

Object ,

Operation Data is output in every sampling (when refreshing the display).

Use this mode to output data to an external display (Data may not be output due to timing of the baud rate and internal sampling rate). If data is printed with pressing the key on the printer, use the stream mode.

Description of "Manual Print"

Object ,

Operation When pressing the key set to output data, the stable weight data is output just once.

Description of "Auto Print Mode"

Object , , or

Operation When the weight data varies from the "inhibit region for output" to the "permission region of output", the stable data is just output once. If you use this mode, set F02 except 0.

For weighing (and removing) each object and printing the data.

In case of ,

"Inhibit region for output" $\leq +5d$ $+5d < \text{"permission region of output"}$.

In case of ,

$-5d \leq \text{"inhibit region for output"} \leq +5d$

$\text{"Permission region of output"} < -5d, +5d < \text{"permission region of output"}$.

d: division (weighing interval) of the first range

Description of "Delay for Continual Data"

Object F38, F42

Operation This function can be used in the "Auto print mode" and "Manual print mode".

When using a non-buffered printer, set to and (or .



6.3. CF-Functions

Item	Parameter	Description
CF00 Zero tracking width, motion detection condition	* 0	No limitation
	1	Use limitation at F01, F02, F03, F27 and F28
CF01 Push zero range	* 0	± 2% of CAP, Tare limit is 100 % CAP
	1	±10% of CAP, Tare limit is 100 % CAP
	2	± 3% of CAP, Tare limit is 50 % CAP
	3	± 4% of CAP, Tare limit is 50 % CAP
CF02 Power on zero range Turning the display on, the range to zero display.	0	Not to zero when turning the display on.
	*1	±10% of CAP
	2	± 3% of CAP
	3	± 4% of CAP
CF03 Zero tracking	0	Gross when displaying gross
	1	Gross
	* 2	Gross or Net when displaying net
CF04 TARE, ZERO in motion / TARE at negative gross value		TARE, ZERO in motion / TARE at negative gross
	* 0	Not to execute / Not to execute
	1	Execute / Not to execute
	2	Not to execute / Execute
	3	Execute / Execute
CF05 Output on overload and unstable state.	* 0	Not to output data at unstable value or overload Effective in key mode
	1	To output data always
CF06 Header 2		GROSS / NET / TARE
	* 0	GS / NT / TR
	1	GS / NT / TR
	2	G_ / N_ / T_ (:Space 20h)
CF07 Number of unit digits	* 0	Two digits
	1	Three digits
CF08 Accumulation function	* 0	Not used (Ineffective)
	1	Used (Effective)

CAP : maximum capacity

*: Initial settings

Power on ZERO (CF02)

CF02=0 After power on, the weight display starts immediately.

CF02=1,2,3 When the zero range is exceeded at power on, is displayed.
Press the key to start the weight display.



7. Function keys F1 and F2

For easier use, select functions of the **F1** key and/or the **F2** key and prioritize them in function settings.

Functions that can be set are as follows:

- “Print 1” or “Print 2” for serial data output in either format 1 or 2
- “Add” for addition
- “totAL” for display of accumulated data
- “SEt Pt” for setting the code memory number and compared data
- “StArt” for starting comparison or batch weighing
- “StoP” for stopping comparison or forced termination of batch weighing
- “bU oFF” for stopping the sound of the comparison buzzer
- “Unit” for changing the unit
- “HoLd” for starting the average or releasing the hold data

The function set as first priority will operated when the **F1** or **F2** key is released and the functions of other priority, by pressing either the **F1** or **F2** key for more than 2 seconds. For further details, refer to each item’s description.

Also, regardless of the function settings above, by pressing both the **F1** and **F2** keys or pressing one key while holding the other key, the following functions can be done.

F1 + F2	Entering function settings
F1 + NET/GROSS	Displaying the accumulated data
F2 + NET/GROSS	Displaying and setting data number
F2 + TARE	Starting batch-weighing
F2 + ON/OFF	Changing the unit



8. Tare

- The function is used to display a net value with the container weight subtracted from the total weight, if you place an object into a container to weigh it.
- Using the serial interface such as RS-232C, you can do this from the external equipment.

Caution □ **When turning the power off, the tare data is cleared. (CF04=0,1)**

Weighing Tare

Operation Place the tare on the weighing unit. Press the **TARE** key to store the tare weight after the STABLE mark turns on. The display changes to net.

Caution □ **When displaying a negative gross value, tare can not be used (normally). To enable tare with a negative gross value, select a CF04 parameter.**

Clearing Tare

- When pressing the **TARE** key while gross is zero, tare is cleared and gross is displayed.
- When zeroing with the **ZERO** key, tare is cleared.



9. Accumulation

The function accumulates weight data and stores the total data and the accumulation count. Data is stored in non-volatile memory, and is not lost even if power is turned off.



9.1. Preparation and Specification

Set the following parameters to use the accumulation function.

- Select CF08 1 for the CF-function so that the accumulation function becomes effective.
- Specify the method of accumulation and data at F20 of the F-function.
- Specify the inhibit region for accumulation at F21 of the F-function.

Selection of Accumulation Mode, F20 of the F-function

- There are two methods of accumulation; manual accumulation using the key assigned to operate the **M+** function and automatic accumulation.
- The accumulated data can select "positive data only" or "both polarity data".
- The accumulated data can select "result of comparison is OK only" or "all result".

Accumulation Condition, F21 of the F-function

- In case of manual accumulation mode, press the key to accumulate weight data when the STABLE mark is displayed.
- Data can be accumulated after the weight data enters the "inhibit region for output". When connecting the power cord and turning the display on, the accumulation mode takes the same action.

Inhibit region for accumulation	F21	Description
Add data anytime	F21 0	Stable data can be used anytime.
Above ± 5 d	F21 1	Initial setting
Above ± 10 d	F21 2	
Above ± 20 d	F21 3	
Above ± 50 d	F21 4	

- Caution**
- **Do not set F21=0 for the automatic accumulation mode.**
 - **If setting F21=0, it may add the same data two times or more.**

Limitation of Accumulation Count and Total

- The limitation of accumulation count is 999999.
The limitation of total is ± 999999 , ignoring the decimal point.
- If exceeding these limitations, the data is not accumulated.
Example: Setting the decimal point to "0.0", the limitation is "99999.9".



9.2. Display and Operation

Action of Accumulating Data

- When accumulating data, the display blinks once.
If the accumulated data is stored, the M+ mark is displayed.

Caution □ **This function can not accumulate data with a different unit. Specify a unit before use.**

Display of Accumulated Data

- When setting to CF08 1 (Effective accumulation function) and pressing the key that allows accumulation display, **totAL** is displayed and the total data is displayed with the M+ mark blinking. Pressing the **TARE** key alternatively displays the accumulated data and the accumulation count.
Pressing the **ESC** key, the weight data is displayed.
- The total data can be output. Refer to "Output of Accumulated Data".

Undoing the Accumulated Data

- The last weight data can be deduced from the accumulated data unless new data has been accumulated.

Step 1 Press the key assigned to operate the function to display **totAL** and the accumulated data.

Step 2 Press and hold the **+/-** key for more than 3 seconds. The display blinks once and the data accumulated before accumulating the last weight data is displayed.

Caution □ **External input can not be used.**

Clearing the Accumulated Data

Step 1 Press the key assigned to operate the function to display **totAL** and the accumulated data.

Step 2 Press and hold the **ZERO** key for more than 3 seconds. The display blinks once and the accumulated data is cleared.

Caution □ **External input can not be used.**

Initializing the Data Number with Clearing the Accumulated Data

- When the data number is included with the data of the serial data output, initializing the data number and clearing the accumulated data can be done at the same time.

Step 1 Press the key assigned to operate the function to display **totAL** and the accumulated data.

Step 2 Press and hold the **ZERO** and **+/-** keys at the same time for more than 3 seconds. The display blinks once and the accumulated data is cleared. And the data number is initialized (1).

Caution □ **External input can not be used.**

Output of Accumulated Data

- The accumulated data can be output to the serial interface.
- Output by manual or automatic, and output data format is selected at F41 of the F-function setting.

F41	Parameter	Manual/Automatic	Format
Accumulated data output at accumulated data display	0	No output	Fixed format
	* 1	Manual (initial setting)	
	2	Automatic	
	3	Manual	Format 1 (selected at F34)
	4	Automatic	
	5	Manual	Format 2 (selected at F35)
	6	Automatic	

Step 1 Press the key assigned to operate the function to display totAL and the accumulated data.

Step 2 If automatic output is set, the data is output once at that timing.

Step 3 If manual output, by pressing the F2 key while the accumulated data is displayed, the data is output.

Fixed data format : Count □□□□N, + 00000001 □ C_RL_F □ Space(20h)

Header Data Terminator

Total T O T A L, + 00000001 k g C_RL_F

Header Data Unit Terminator



10. Code Memory

- The AD-4406 has four Code memories (1 through 4). Each Code memory stores a set of setpoints.
- The data is stored in non-volatile memory, and is not lost even if power is turned off.
- Memory number 0 is a temporary memory and the data is lost when power is turned off.
- The active code memory number can be changed by key switch, external control input, or a command via the serial interface.

Changing the Code Memory Number by External Input

- The code memory number can be changed by external input from OP-05 or OP-08.

- Set F14 and F15 to 18.
- F13=18 : Inhibit reading EXT.2 and EXT.3 to prevent unintentional reading when switching the codes.

EXT2	EXT3	Memory Number
ON	ON	1
OFF	ON	2
ON	OFF	3
OFF	OFF	4



11. Comparison

- This function has the "upper / lower limit comparison", the "5-stage (HiHi/Hi/OK/Lo/LoLo) comparison", the "setpoint comparison" and the "simple batch". They compare the weight data with preset parameters and can output the result of the comparison to the display and buzzer, also to the relay-outputs of OP-03, OP-05 and OP-08.
- Set the F-function F22 and F23 to use the "upper / lower comparison", the "5-stage (HiHi/Hi/OK/Lo/LoLo) comparison" (these two comparison methods will be combined and hereafter be called the "Weight check mode"), and F22 through F26 to use the "setpoint comparison" and the "simple batch".
- There are four code memories for the setpoints. Data is stored in non-volatile memory and is not lost even if power is turned off or the batteries are depleted.
- Code memory can be selected by key switch, external control input, or a command via the serial interface.



11.1. Weight Check Mode

- This function compares the weight data with the upper and lower limit values (upper/lower limit comparison) or with four limit values of HiHi, Hi, Lo and LoLo (5-stage comparison), and displays, sounds the buzzer and/or outputs the result to the three relays of HI, OK and LO. Use this comparison when judging whether a weight is proper.
 - Set the F-function F22 to 1, 2 or 3 to use the upper/ lower limit comparison and F22 to 4, 5 or 6 to use the 5-stage comparison.
 - Select a parameter of the F-function F23 for the comparison condition.
 - Set the F-function F26 (zero band) if setting F23:10 (not compared in the zero band).
 - Specify the upper and lower limit / HiHi, Hi, Lo, LoLo limit values.
 - When entering the limit value(s), it is not necessary to enter the F-function F22 and F23 again unless comparison conditions are changed.
 - There are 3 type of setting values for each comparison.
 - (1) Set the limit value (upper and lower limit / HiHi, Hi, Lo, LoLo limit).
 - (2) Set the Target value and an acceptable tolerance (upper and lower) in weight.
The limit value is calculated automatically.
 - (3) Set the Target value and an acceptable tolerance (upper and lower) in percentage of the target weight. The limit value is calculated automatically.
- Example. Target = 50 kg, Upper limit = 51 kg, Lower limit = 48 kg
- (1) Hi (Upper limit) : 51 (kg), Lo (Lower limit) : 48 (kg)
 - (2) TG (Target) : 50 (kg), Hi (Upper acceptable tolerance) : 1 (kg),
Lo (Lower acceptable tolerance) : 2 (kg) not a negative value
 - (3) TG (Target) : 50 (kg), Hi (Upper acceptable tolerance) : 2 (% of Target),
Lo (Lower acceptable tolerance) : 4 (% of Target) not a negative value

11.1.1. Condition Formula for Comparison

Comparison is performed based on the following formula.

Upper/lower limit comparison

Judge	Condition Formula	Display	Output
HI	Upper limit (Hi limit) value < Displayed value	HI	HI
OK	Lower limit value ≤ Displayed value ≤ Upper limit value	OK	OK
LO	Displayed value < Lower limit (Lo limit) value	LO	LO

5-stage comparison

Judge	Condition Formula	Display	Output
HiHi	HiHi limit value < Displayed value	HI, ▼2	HI
HI	Upper limit (Hi limit) value < Displayed value	HI	HI, OK
OK	Lower limit value ≤ Displayed value ≤ Upper limit value	OK	OK
LO	Displayed value < Lower limit (Lo limit) value	LO	LO, OK
LoLo	Displayed value < LoLo limit value	LO, ▼3	LO

- The decimal point is not considered. Example: If the upper limit value is 10.0, enter 100.
- These parameters are stored in non-volatile memory, and are not lost even if power is turned off or the batteries are depleted.
- When the displayed value becomes an overload (positive over), HI (over) is output. When the displayed value becomes an under load (negative over), LO (under) is output.
- This function compares the upper limit value first.
- This function does not check the relationship between the upper and lower limit values.

11.1.2. Setting the Upper/Lower Limit Values

Step 1 Press and hold the setpoint setting function key, that function is activated. When **SEt Pt** appears, release the key switch. The indicator enters the setpoint setting mode and the display code memory number blinks.

Step 2 Set the code memory number using the following keys.

> key To select a comparison class and proceed to step 3.

^ key..... To select a code memory number.

ESC key. To return to the weight display without changing code memory.

ENTER key To set the displayed code memory's setpoint and return to the weight display.

Step 3 Select the comparison class (upper limit value etc.) using the following keys.

> key To select a comparison class (blinking).

ESC key To return to step 2.

ENTER key To proceed to step 4.

Step 4 Set the setpoint value using the following keys.

 key To select a digit.

 key..... To select a value.

 key To store the parameter and return to step 3.

 key To return to step 3 without changing the parameter.

Setting Order and Display for the Weight Check Mode

F22	MODE	Display	1	2	3	4	5	
1	Upper	Setpoint	Upper	Lower				
	Lower	Class	Hi	Lo				
		1	Comparator	HI	LO			
2	Upper	Setpoint	Target	Upper	Lower			
	Lower	Class	tG	Hi	Lo			
		2	Comparator	OK	HI	LO		
3	Upper	Setpoint	Target	Upper	Lower			
	Lower	Class	tG	Hi	Lo			
		3	Comparator	OK	HI	LO		
			Unit		%	%		
4	5-stage	1	Setpoint	HiHi	Hi	Lo	LoLo	
			Class	HH	Hi	Lo	LL	
			Comparator	HI	HI	LO	LO	
			Triangle	2			3	
5	5-stage	2	Setpoint	Target	HiHi	Hi	Lo	LoLo
			Class	tG	HH	Hi	Lo	LL
			Comparator	OK	HI	HI	LO	LO
			Triangle		2			3
6	5-stage	3	Setpoint	Target	HiHi	Hi	Lo	LoLo
			Class	tG	HH	Hi	Lo	LL
			Comparator	OK	HI	HI	LO	LO
			Unit		%	%	%	%
			Triangle		2			3



11.2. Setpoint Comparison

- This function includes the weighing sequence and uses for acquiring a preset target weight.
- There are four parameters of "Final", "Preliminary", "Free fall" and "Zero band" to use the setpoint comparison.
- The result of the sequence is output to three relays of OP-03, OP-05 or OP-08.
- When entering these parameters, it is not necessary to enter the F-function F22 again unless comparison conditions are changed.

11.2.1. Description of Input Parameters and Outputs

F22 = 7 (Check weighing 1)

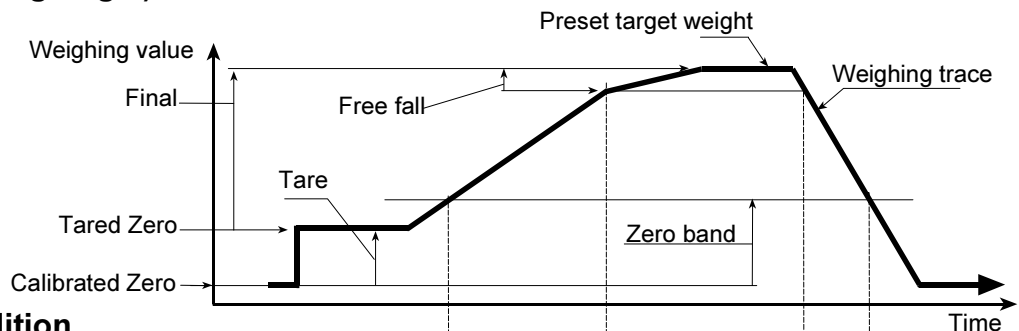

Output and Condition

Relay HI, ▼1, $\text{Net} \geq (\text{Final} - \text{Free fall})$	OFF	ON	OFF
Relay LO, ▼3, $\text{Gross} < \text{Zero band}$	ON	OFF	ON

Relay OK output can be changed to OVER or UNDER by setting F24. The triangle 2 is not displayed.

OVER/UNDER is judged always and the result is output to the display and the relay.

F22 = 8 (Check weighing 2)

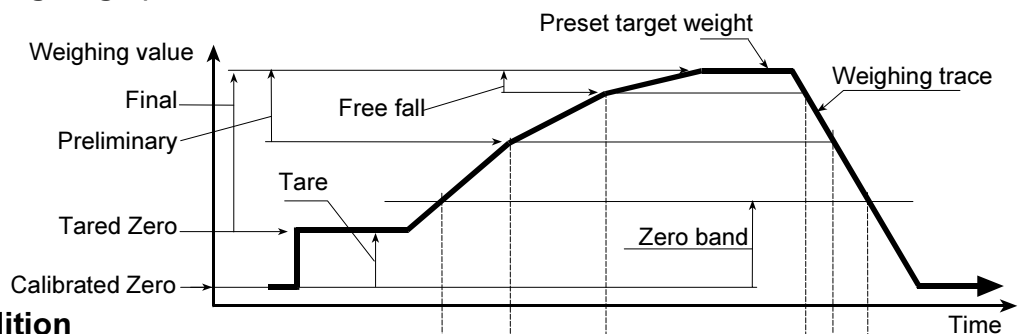

Output and Condition

Relay HI, ▼1, $\text{Net} \geq (\text{Final} - \text{Free fall})$	OFF	ON	OFF
Relay OK, ▼2, $\text{Net} \geq (\text{Final} - \text{Preliminary})$	OFF	ON	OFF
Relay LO, ▼3, $\text{Gross} < \text{Zero band}$	ON	OFF	ON

OVER/UNDER is judged always and the result is output to the display but not to the relay.

F22 = 9 (Check weighing 3: Loss in weight)

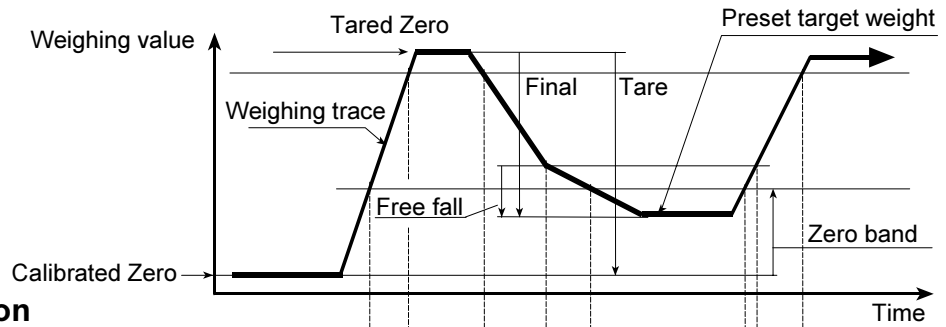

Output and Condition

Relay HI, ▼1, $-Net \geq - (Final - Free\ fall)$	OFF		ON		OFF
Relay LO, ▼3, $Gross < Zero\ band$	ON	OFF		ON	OFF
Relay OK*, ▼2, $Gross \geq Full$	OFF	ON	OFF		ON

* Relay OK output can be changed to OVER or UNDER by setting F24.

Triangle 2 is displayed when $Gross \geq Full$ regardless of the F24 setting.

OVER/UNDER is judged always and the result is output to the display and the relay.

11.2.2. Simple Batch

The weighing sequences of simple batch (F22=10, 11 or 12) are similar to those of Check weighing (F22=7, 8 or 9) respectively. The differences are listed below.

- 1 Basically ON/OFF of the relay and the display is reversed.
- 2 No judgment other than Zero band and Full before input Start signal.
- 3 The weighing completion condition is set by F23: 2x and it is effective after Start.
- 4 The outputs of Preliminary and Free fall are off from weighing completion to the next start.
- 5 Weighing completion can be output by setting F24 and F25.
- 6 The start signal can be accepted after weighing completion even if the weight is not within the zero band.
- 7 Over/Under output is set by F23: 3x.

Start

Tare, when the Start is input automatically, if F23 is set to 11.

The READY mark turns off when the Start is input.

Weighing Completion

The weighing completion condition is set by F23: 2x.

F23 20 : Either the STOP key is pressed or the Batch stop input is on

F23 21 : Stable is detected after reaching Final

Before reaching Final, the STOP key or Batch stop input forces weighing completion even if F23 is set to 21.

Toward the Zero band

Preliminary and Free fall output are holding the off state.

Over/Under comparison starts. If F23 is set to 30, judgment starts when Free fall turns on. The judgment is not latched and the output is according to the state at the time.

The Weighing completion relay is turned on if F24 is set to 2. The on time is set by F25.

The READY mark is blinking regardless of the settings of F24 and F25.

Start is may be accepted at this state.

Returns to Zero band

Over/Under and Weighing completion output is off.

The READY mark is turned on.

11.2.3. Setting the Parameters of Setpoint Comparison

Refer to "11.1.2. Setting the Upper/Lower Limit Values".

Zero band value is set at F26 of the F-Functions, and the value does not belong to a specific code memory, but is used commonly.

Setting Order and Display for Setpoint Comparison and Simple batch

F22	MODE	Display	1	2	3	4	5
7	Setpoint Comparison 1	Setpoint	Final	Free fall	Over	Under	
		Class	Fi	FF	Hi	Lo	
		Comparator	OK		HI	LO	
		Triangle		1			
8	Setpoint Comparison 2	Setpoint	Final	Free fall	Preliminary	Over	Under
		Class	Fi	FF	Pr	Hi	Lo
		Comparator	OK			HI	LO
		Triangle		1	2		
9	Setpoint Comparison 3	Setpoint	Final	Free fall	Full	Over	Under
		Class	Fi	FF	Fu	Hi	Lo
		Comparator	OK			HI	LO
		Triangle		1	2		
10	Simple Batch 1	Setpoint	Final	Free fall	Over	Under	
		Class	Fi	FF	Hi	Lo	
		Comparator	OK		HI	LO	
		Triangle		1			
11	Simple Batch 2	Setpoint	Final	Free fall	Preliminary	Over	Under
		Class	Fi	FF	Pr	Hi	Lo
		Comparator	OK			HI	LO
		Triangle		1	2		
12	Simple Batch 3	Setpoint	Final	Free fall	Full	Over	Under
		Class	Fi	FF	Fu	Hi	Lo
		Comparator	OK			HI	LO
		Triangle		1	2		



12. Hold Function

- This function displays the hold weight data after averaging the weight data for a specific period.
- Useful to determine a living animal's weight.
- Averaging time is selectable up to 9.9 seconds by 0.1 second step.
- 3 methods are available to start averaging; manual start, automatic start after stable, and manual / automatic start.
- Manual start is available with key switch or external input.
- Serial interface commands are also available; averaging start, releasing the hold data and outputting the hold state. Refer to “13.3.4. Commands for Hold Function”.

Caution

- **This function can not be used under the setting CF00=1**
- **Averaging can not start at a displayed value smaller than 0 +/- 5 digits.**
- **Data when the display is over is not included for averaging.**
- **When powered off, the hold is released automatically.**
- **There is no peak hold function.**

The display and the Data Output of Hold and Average

- The weight display is blinking during the averaging period.
- The output data in the averaging period is the actual weight at the time.
- The weighing unit is blinking when the weight display is in the hold state.
- The output data format of the hold weight data is the same as that of the normal weight data except the header of stable state is “HD” in the response to the “RW” or “RW,n” (n=1 or 2) command.

Relations to the Other Functions

- If automatic accumulation (F20:21) and/or auto print (F37=2,3 F40=2,3) is set, accumulation and/or data output is performed after determining the hold data.



12.1. Setting the Hold Functions

- F27 determines the method of starting the average.
 - F27=1 Manual start: Starts the average and release with key switch operation.
 - F27=2 Automatic start: After passing the inhibit region * and detect stable **, starts the average automatically, releasing the data when the weight returns to inhibit region.
 - F27=3 Both Manual start and Automatic start.
 - *inhibit region 0 +/- 5digits
 - **stable detection Satisfied both F02 and F03
- F28 determines the averaging time by 0.1second step. F28=0 holds the data at averaging start.

- The key switch will function as the HOLD key if F10 or F11 parameter is set to A.
- The external input function of averaging start is 19 and hold release is 20 of F13, F14 and F15. The function is accepted at the off to on edge of the external input.

Conditions of the Average and Release

The method to start/stop the average and to release the hold state depends on the F27 setting.

Condition	F27=1	F27=2	F27=3
Average start in the inhibit region	No	No	No
Average start with key switch (including unstable)	Yes	No	Yes
Average start with ext. input (including unstable)	Yes	No	Yes
Average start with command (including unstable)	Yes	Yes	Yes
Average start after passing the inhibit region and stable	No	Yes	Yes
Weight is entering the inhibit region at averaging	Continue	Stop	Stop
Weight is going to over at averaging	Pending	Stop	Pending
Hold key input at averaging	Stop	Stop	Stop
Release input from external input at averaging	Stop	Stop	Stop
Release command input at averaging	Stop	Stop	Stop
Hold key input at hold	Release	Release	Release
Release input from external input at hold	Release	Release	Release
Release command input at hold	Release	Release	Release
Weight is entering the inhibit region at hold	Continue	Release	Release
Weight is going to over at hold	Continue*	Continue*	Continue*

Pending: Suspend the count up timer and do not average under the condition.

Release: Key, ext. input and command are effective at over display.

Continue*: Continue hold, but over display.

Key Input and Command in the Hold State

Release hold and perform key function:

Keys: TARE, ZERO, SETPOINT, TOTAL

Commands: MT, MZ, HC

Continue hold and perform key functions

Keys: NET/GROSS, Accumulation, Compare start/stop

Commands: Other commands



13. RS-232C Interface (OP-04, OP-05, OP-08)



13.1. Specifications

Transmission	Asynchronous, bi-directional, half-duplex
Baud rate	600, 1200, 2400, 4800, 9600 bps
Data bits	7 bits, 8 bits
Parity bits	1 bit, Even or Odd (for 7 data bits) or Non parity (for 8 data bits)
Start bit	1 bit
Stop bit	1 bit
Code	ASCII
Terminator	CR LF, CR (CR: 0Dh, LF: 0Ah)
Connector	D-sub 9 pin connector

Circuit and Pin Connection

Pin No.	Signal name	Direction	Description
2	TXD	Output	Transmit data
3	RXD	Input	Received data
5	SG	-	Signal ground
6	DSR	Output	Data set ready
7	RTS	-	Pin 7 is connected to pin 8
8	CTS		
Other			Not used
Case			Shield

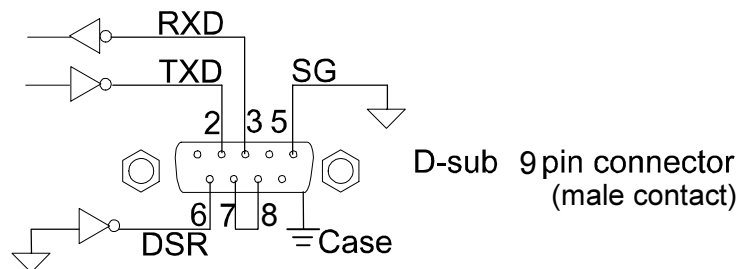

Bit Format

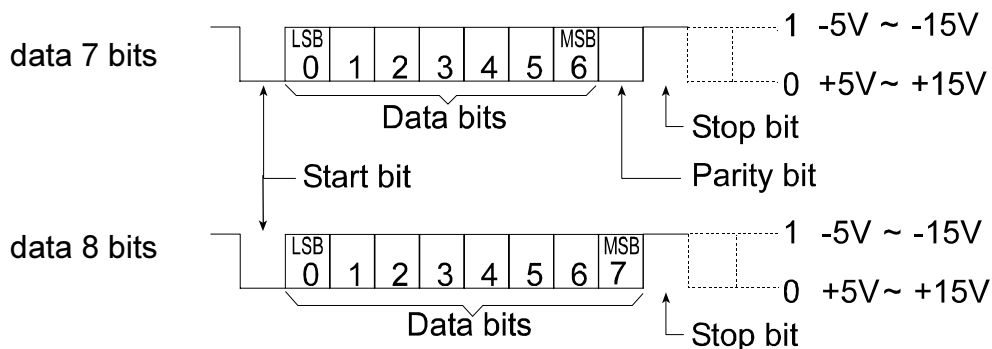



13.2. Data Format

- There are two types of data format set at F-Function F34 and F35.
- The initial data format of F34 is shown below.

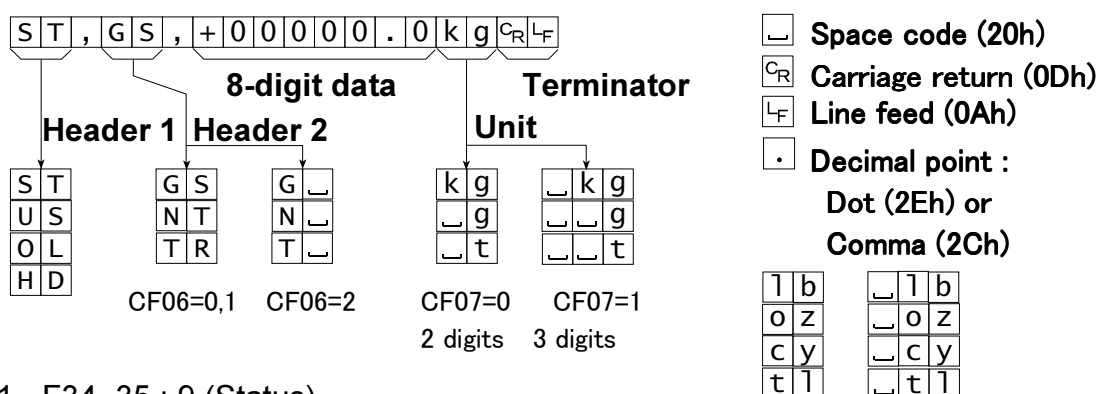

Header 1 F34, 35 : 9 (Status)

- ST Stable weight data.
- US Unstable weight data.
- OL Overload (Out of range).
- HD Hold weight data (The response of the "RW" and "RW,n" command).

Header 2 F34, 35 : E (Weight type)

- GS or G Gross data.
- NT or N Net data
- TR or T Tare data.

Data F34, 35 : A, B, C, D (Weight data)

The first of the data bits is the polarity, "+" or "-".

When data is zero, the polarity is "+".

8 digits (bits) including the polarity and a decimal point (dot or comma).

In case of "Out of range", the data bits are replaced by spaces except for the decimal point.

Unit F34, 35 : F (Unit)

In case of CF07=0, the unit length is 2 digits.

In case of CF07=1, the unit length is 3 digits. Depending on the circumstances, an A&D printer may not work correctly.



13.3. Command Format

Description of Command

- When performing a command, the received command or reply data is sent back.
- When the received command can not be performed such as the "busy" state, the code " I " is sent back. In this case, insert a delay time. Electrical noise may be the cause of this error.

- When receiving an undefined command (unknown command), a "?" is sent back.
- When the memory is short to store the data of UFC commands, an "M" is sent back.
- Optional addresses can be appended to a command. The address form is "@address" and the address is specified at F-Function F06. The reply (data or error code) is also sent with the address.

Example: Command is "Display net data". Address is 23.

Sending a command

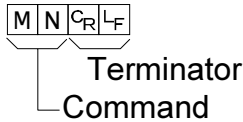

Sending a command with address

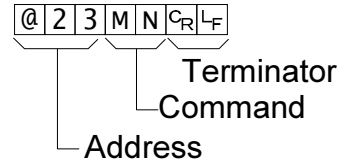

Unperformed command reply

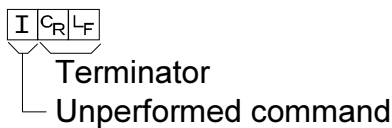

Unknown command reply

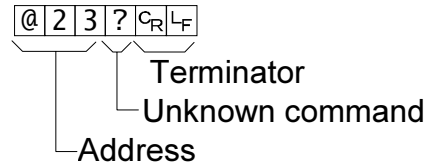

Memory overflow (for UFC commands)

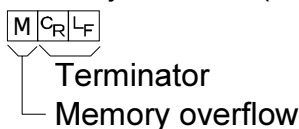

- C_R Carriage return (20h)
- L_F Line feed (0Ah)

13.3.1. Commands to Request Data

Request Display Data (1)

When receiving this command, returns the displayed data immediately.

Template RW

Command $R W C_R L_F$

Reply $S T , G S , + 0 0 1 2 3 . 0 k g C_R L_F$

Request Display Data (2)

When receiving this command, returns the displayed data immediately with format 1 or 2.

Template RW,1 or RW,2

Command $R W , 1 C_R L_F$ or $R W , 2 C_R L_F$

Reply Format 1 (F34) or Format 2 (F35)

Request Gross Data

When receiving this command, returns the gross data immediately.

Template RG

Command $R G C_R L_F$

Reply $S T , G S , + 0 0 1 2 3 . 0 k g C_R L_F$

Request Net Data

When receiving this command, returns the net data immediately.

Template RN

Command

R	N	C _R	L _F
---	---	----------------	----------------

Reply

S	T	,	N	T	,	+	0	0	1	2	3	.	0	k	g	C _R	L _F
---	---	---	---	---	---	---	---	---	---	---	---	---	---	---	---	----------------	----------------

Request Tare Data

When receiving this command, returns the tare data immediately.

Template RT

Command

R	T	C _R	L _F
---	---	----------------	----------------

Reply

S	T	,	T	R	,	+	0	0	1	2	3	.	0	k	g	C _R	L _F
---	---	---	---	---	---	---	---	---	---	---	---	---	---	---	---	----------------	----------------

Request Accumulated Data

When receiving this command, returns the accumulated data immediately.

Template RA

Command

R	A	C _R	L _F
---	---	----------------	----------------

Reply Refer to the Fixed data format of "9.2. Display and Operation, Output of Accumulated Data".

Is Zero

When receiving this command, returns "at zero point" or no immediately.

Template RZ

Command

R	Z	C _R	L _F
---	---	----------------	----------------

Reply

1	C _R	L _F
---	----------------	----------------

 When at ZERO

0	C _R	L _F
---	----------------	----------------

 Not at ZERO

13.3.2. Commands to Control the Indicator

Zero Display

Sets the current display to the zero point.

Template MZ

Command

M	Z	C _R	L _F
---	---	----------------	----------------

Reply

M	Z	C _R	L _F
---	---	----------------	----------------

Tare

Sets the current display to zero of the net data.

Template MT

Command

M	T	C _R	L _F
---	---	----------------	----------------

Reply

M	T	C _R	L _F
---	---	----------------	----------------

Clear Tare Data

Clears the tare data and displays the gross data.

Template CT

Command

C	T	C _R	L _F
---	---	----------------	----------------

Reply

C	T	C _R	L _F
---	---	----------------	----------------

Display Gross Data

Displays the gross data.

Template MG

Command

M	G	C _R	L _F
---	---	----------------	----------------

Reply

M	G	C _R	L _F
---	---	----------------	----------------

Display Net Data

Displays the net data.

Template MN

Command

M	N	C _R	L _F
---	---	----------------	----------------

Reply

M	N	C _R	L _F
---	---	----------------	----------------

Accumulation (M+)

Accumulates the displayed data.

Template MA

Command

M	A	C _R	L _F
---	---	----------------	----------------

Reply

M	A	C _R	L _F
---	---	----------------	----------------

Clearing the Accumulated Data

Clears the accumulated data.

Template CA

Command

C	A	C _R	L _F
---	---	----------------	----------------

Reply

C	A	C _R	L _F
---	---	----------------	----------------

Changing the Weight Unit

Changes the weight unit.

Template UC

Command

U	C	C _R	L _F
---	---	----------------	----------------

Reply

U	C	C _R	L _F
---	---	----------------	----------------

Changing the Code Memory

Changes the Code Memory number.

Template SC,m

m: code memory number, 0 - 4

Command

S	C	,	2	C _R	L _F
---	---	---	---	----------------	----------------

Reply

S	C	,	2	C _R	L _F
---	---	---	---	----------------	----------------

Disabling Key Switches

Disables the key switches. Once power off, no effect by this command.

Template DK,n

n: key switch number (0: all key, 1 - 6: refer to F-Function F12)

Command

D	K	,	2	C _R	L _F
---	---	---	---	----------------	----------------

 Example: to disable TARE key

Reply

D	K	,	2	C _R	L _F
---	---	---	---	----------------	----------------

Enabling Key Switches

Enables the key switches that are disabled by the DK command. Not applicable to the keys disabled by F12.

Template EK,n

n: key switch number (0: all keys, 1 - 6: refer to F-Function F12)

Command

E	K	,	0	C _R	L _F
---	---	---	---	----------------	----------------

 Example: to enable all keys

Reply

E	K	,	0	C _R	L _F
---	---	---	---	----------------	----------------

13.3.3. Commands to Set Parameters

Set Limit/Setpoint Value

Sets the limit or setpoint value of the comparison. The decimal point is not necessary.

Template S_m,n, [value]

m: code memory number, 0 - 4

n : setpoint order number, refer to "Setting the setpoint"

Command

S	1	,	3	,	+	1	6	0	C _R	L _F
---	---	---	---	---	---	---	---	---	----------------	----------------

Reply

S	1	,	3	,	+	1	6	0	C _R	L _F
---	---	---	---	---	---	---	---	---	----------------	----------------

Set Zero Band

Sets the F26 value (zero band) of the comparison. The decimal point is not necessary.

Template SZ, [value]

Command

S	Z	,	+	7	4	8	C _R	L _F
---	---	---	---	---	---	---	----------------	----------------

Reply

S	Z	,	+	7	4	8	C _R	L _F
---	---	---	---	---	---	---	----------------	----------------

13.3.4. Commands for Hold Function

Start Averaging to Hold

Starts averaging to hold. The reply differs with the conditions.

Template HS

Command

H	S	C _R	L _F
---	---	----------------	----------------

Reply

H	S	C _R	L _F
---	---	----------------	----------------

 Averaging start

H	D	,	1	C _R	L _F
---	---	---	---	----------------	----------------

 Averaging now

H	D	,	2	C _R	L _F
---	---	---	---	----------------	----------------

 Hold

Release the Hold Data

Releases the hold data or stops averaging and goes to the normal weighing mode.

Template HC

Command

H	C	C _R	L _F
---	---	----------------	----------------

Reply

H	C	C _R	L _F
---	---	----------------	----------------

Request Hold State

When receiving this command, returns the average/hold state immediately.

Template HD

Command

H	D	,	0		C _R	L _F
---	---	---	---	--	----------------	----------------

Reply

H	D	,	0		C _R	L _F
---	---	---	---	--	----------------	----------------

 Not hold nor averaging

H	D	,	1		C _R	L _F
---	---	---	---	--	----------------	----------------

 Averaging now

H	D	,	2		C _R	L _F
---	---	---	---	--	----------------	----------------

 Hold

13.3.5. Commands to Set Serial Data Output Format (UFC)

Set Serial Data Format

Sets the serial output data format.

Format 1 data is stored in the same memory area of F34 and format 2 data is stored in the same memory area of F35.

Template SFf, [parameters]

f: Format number, 1 or 2

Command

S	F	1	,	\$	G	R	C _R	L _F
---	---	---	---	----	---	---	----------------	----------------

Reply

S	F	1	,	\$	G	R	C _R	L _F
---	---	---	---	----	---	---	----------------	----------------



13.4. UFC Command

- UFC (Universal Flexi Coms) function enables editing the serial data output format freely using the serial interface command.
- For customizing the print out of the printer or efficient data collection.
- Output data is not only the indicator's data/status, but also the characters at will.
- It can output the control code* of the printer. (* depends on individual printer)
- There are 2 sets of memories for storing the parameters.

UFC Command Parameter

UFC commands such as SF1 have many parameters.

- One command line can have multiple parameters. The parameters are stored in memory in order.
- Multiple UFC commands are possible. The parameters are stored next to the last parameter stored by the last UFC command.
- Clear all of the data first, if storing a new set of parameters. The parameters in the stored data can not be changed partially.
- The various types of parameters and their descriptions are shown on the following page.

data	Weight, result of comparison etc.
\$CL	CLear previous settings. The UFC command parameters can not be changed partially.
\$WT	Displayed data
\$GR	GRoss data
\$NT	NeT data
\$TR	TaRe data
\$HD	Header of Gross/Net/Tare. Refer to CF06.
\$UT	Weight UniT
\$ST	STable/Unstable
\$CP	Result of ComParison
\$ID	ID number specified at F06
\$DN	Data Number increments with each output automatically
\$CD	CoDe memory number
\$AN	Accumulation count
\$TL	TotaL weight
\$CM	CoMma
\$CR	CR code (0Dh)
\$LF	LF code (0Ah)
\$DE	DElete the last parameter
\$DL	Inserting DeLay time (0.1 second step) Example: DL10 : 1.0 second delay

strings Output the specified strings, enclosed by single quotation (').
 ' itself is described using three single quotations; '''
 Example: 'A & D'
 Set data bits = 8 bits if using the 8-bit characters.

hexadecimal Control code of the printer etc, preceded by #.
 2 characters preceded by # is hexadecimal code (0 - 9, A - F).
 Example: #09
 The #FF code can not be used because it is used for internal control.

□ Example

SF1,\$ID\$DN\$CR\$LF\$GR\$UT\$CR\$LF

Serial output data format 1, ID number, data number, carriage return and line feed, Gross weight, unit, carriage return and line feed.

SF2,' Welcome to A & D'\$LF'Total weight '\$AN\$TL\$LF\$LF

Serial output data format 2, the strings ' Welcome to A & D' and line feed, the strings 'Total weight ' accumulation count, total weight, and 2 sets of line feed.



14. RS-422/RS-485, Relay Output (OP-03)

- Replacing the RS-232C interface with this option, the RS-422/RS-485 interface can connect up to 32 indicators and control them from a computer or a PLC.
- The functions of the RS-422/RS-485 interface are common to RS-232C except the signal system.
- The relays output the result of comparison.

Solid-state-relay

Maximum voltage 50VDC

Maximum current 100 mA DC

Maximum resistance 8 Ω

- Pin connections

Function	Pin No.	Signal name	Direction	Description
RS-422 RS-485	1	SDA	Output	Transmission A terminal
	2	SDB	Output	Transmission B terminal
	3	RDA	Input	Receive A terminal
	4	RDB	Input	Receive B terminal
	5	TRM	-	Terminator resistance (100 Ω)
	6	SG	-	Signal ground
Relay output	7	HI	Output	Relay output HI
	8	OK	Output	Relay output OK
	9	LO	Output	Relay output LO
	10	COM	-	Relay output common

- Adaptable connector TM-BLA10 (an accessory)
- An AC adapter (an accessory) must be connected to the option board when using the RS-422 or RS-485 interface. If using relay output only, the AC adapter is not required.

Circuit

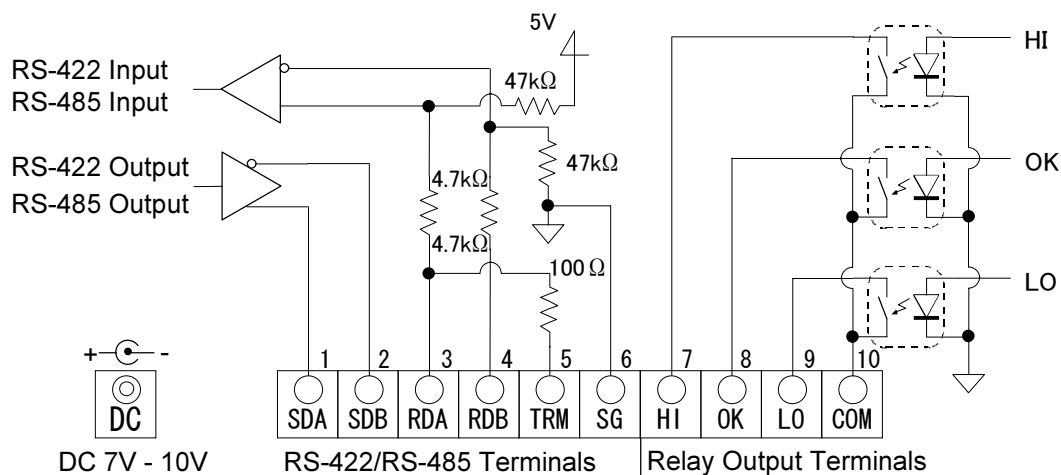

DC 7V - 10V
AC adapter Jack

(AC adapter is an accessory of OP-03)

Note: Please confirm that the AC adapter type is correct for your local voltage and receptacle type.

Switching Between RS-422/RS-485

Switching between RS-422/RS-485 is made with the slide switch (S1) on the OP-03 board.

Connection

- The polarity of signals A and B may vary with different computers.
- It is not necessary to ground the SG terminal when using a computer without a signal ground terminal.

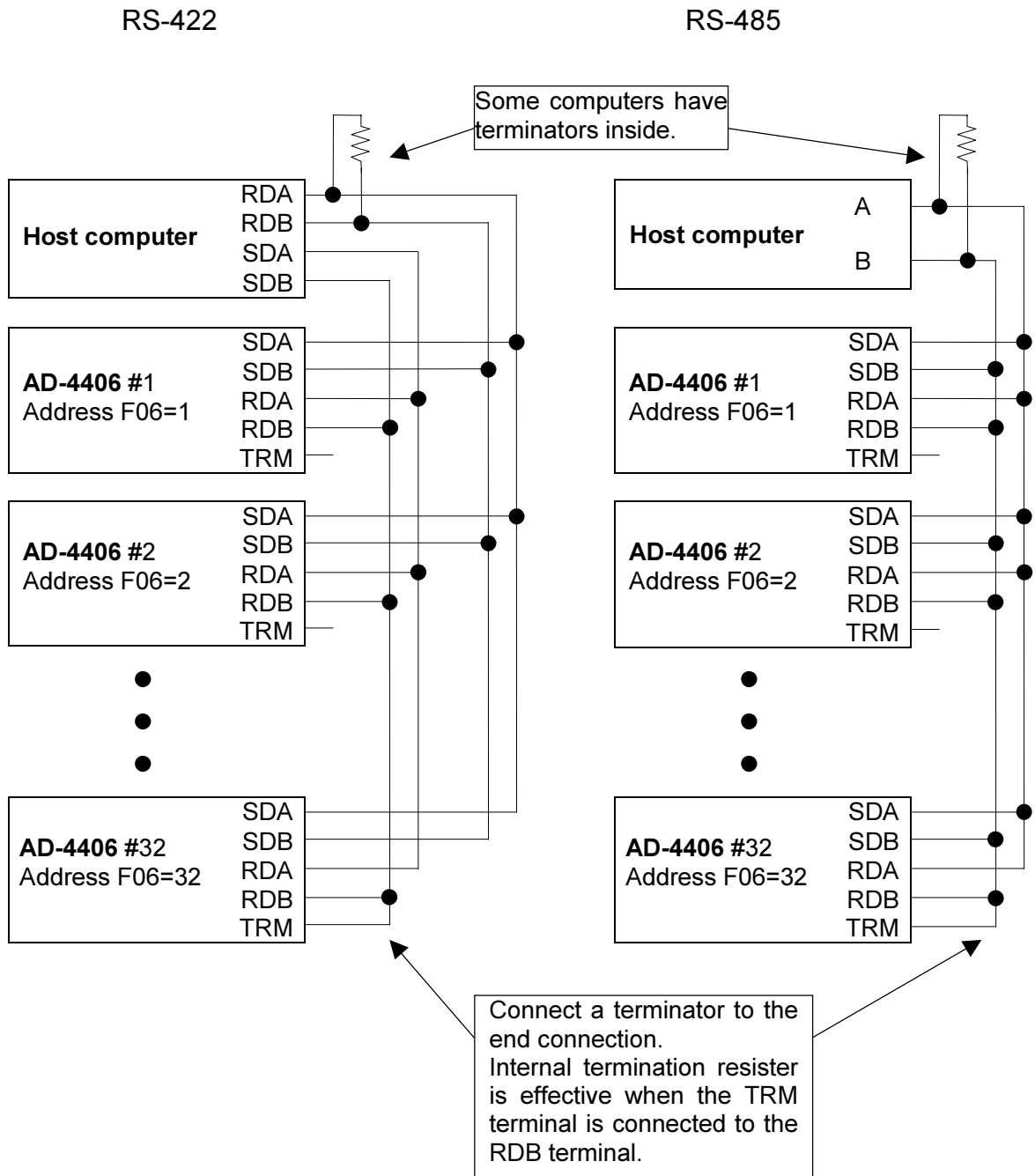



15. Relay Output & Control Input (OP-05)

- Replacing the RS-232C interface with this option, 3-relay outputs and 3-control inputs can be used with the RS-232C interface of this option.
- RS-232C functions and pin connections are the same as the RS-232C interface described in “13. RS-232C Interface (OP-04, OP-05, OP-08)”.
- The control inputs can control the indicator from an external terminal just like the front panel key operations.
- Set the external control functions at F13 - F15 of the F-Functions.
- When connecting each function pin to the common pin, the indicator makes the action.
- Keep a signal width of more than 100 ms for the On-time and Off-time.

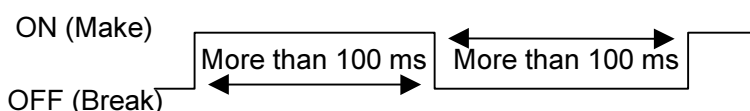

- The relays output the result of comparison.

Solid-state-relay

Maximum voltage 50VDC

Maximum current 100 mA DC

Maximum resistance 8 Ω

- Pin connections (DIN 8 pin connector)

Function	Pin No.	Signal name	Direction	Description
Relay output	1	HI	Output	Relay output HI
	6	OK	Output	Relay output OK
	4	LO	Output	Relay output LO
	8	COM (out)	-	Relay common terminal
Control input	3	EXT1	Input	Control input 1 (F13)
	5	EXT2	Input	Control input 2 (F14)
	7	EXT3	Input	Control input 3 (F15)
	2	COM (in)	-	Control input common

- Adaptable connector JA-TCP0586 (an accessory)

Circuit

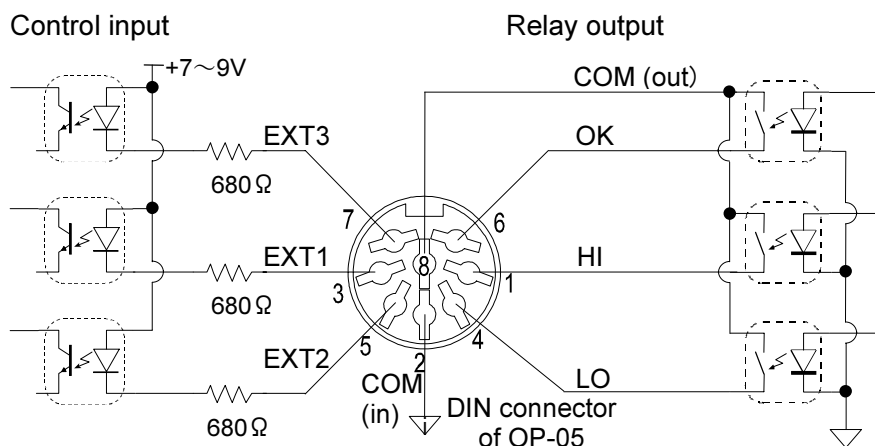



16. 4–20 mA Analog Output (OP-07)

- The OP-07 analog output option is for sending the weight data to an analog input unit.
- The output is a 4 mA to 20 mA current output proportional to the display reading.
- The output data is updated in synchronization with the display update.

Specifications

Output current	4 mA to 20 mA *	Non-linearity		Less than +/- 0.1% fs
Load resistance	0 to 510 Ω	Temperature coefficient	ZERO	Less than +/- 0.02% fs/C
Resolution	Approx. 1/10000		SPAN	Less than +/- 0.02% fs/C
Output terminal	Connector terminal No.1 : + No.2 : - No.3 : FG (Earth)			
Accessory	Connector terminal (1) TM-MSTB03STF AC adapter (1) Note: Please confirm that the AC adapter type is correct for your local voltage and receptacle type.			

* When set to a non-weight display (Calibration, F-settings etc.), the output current is 4 mA. The output current is not adjustable.

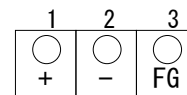
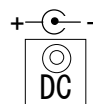

DC 7V - 10V
AC adapter Jack

Analog output terminal

Settings

Set F30 of the F-Functions to 1, and set F31, F32 and F33.

	Item	Parameter	Remarks	
Data output	F30 Data output	* 0	No output	Initial setting
		1	Analog output	Must be set to 1
		2	Serial in/out 1	
		3	Serial in/out 2	
Analog output	F31 Output data	* 0	Displayed value	Initial setting
		1	Gross weight	
		2	Net weight	
	F32 Weight value at 4 mA	-999999 to 999999 (Initial setting is 0)	Decimal point is set at "CALSET"	
F33 Weight value at 20 mA	-999999 to 999999 (Initial setting is 10000)	Decimal point is set at "CALSET"		

Settings of F32 and F33

When entering the F32 or F33 settings (press the **ENTER** key when "32" or "33" is blinking), the setting value is displayed. Select the blinking digit by pressing the **>** key and increase the value by pressing the **^** key. By pressing the **+/-** key, the polarity of the value can be alternated. Press the **ENTER** key to store the setting value into memory. After this the display returns to selection of the Function number.

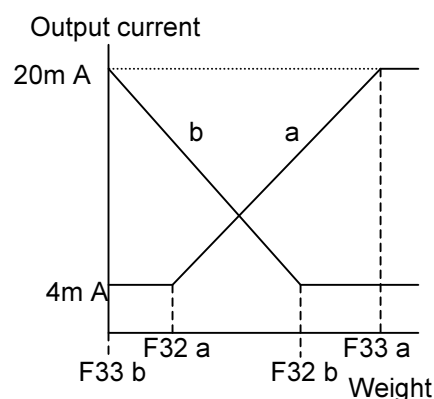



17. Current Loop Output (OP-08)

- Replacing the RS-232C interface with this option, current loop output, 3-relay outputs and 1-control input can be used with the RS-232C interface of this option.
- RS-232C functions and pin connections are the same as the RS-232C interface described in “13. RS-232C Interface (OP-04, OP-05, OP-08)”.
- The control input can control the indicator from an external terminal just like the front panel key operation.
- Set the external control functions at F15 of the F-Functions.
- When connecting the function pin and the common pin, the indicator makes the action.
- Keep a signal width of more than 100 ms for the On-time and Off-time.

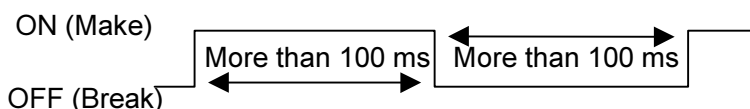

- The relays output the result of comparison.

Solid-state-relay

Maximum voltage 50VDC

Maximum current 100 mA DC

Maximum resistance 8 Ω

- Pin connections (DIN 8 pin connector)

Function	Pin No.	Signal name	Direction	Description
Relay output	1	HI	Output	Relay output HI
	6	OK	Output	Relay output OK
	4	LO	Output	Relay output LO
	8	COM (out)	-	Relay common terminal
Current loop	3	CL1	Output	Current loop output 1
	5	CL2	Output	Current loop output 2
Control input	7	EXT3	Input	Control input 3 (F15)
	2	COM (in)	-	Control input common

- Adaptable connector JA-TCP0586 (an accessory)

Circuit

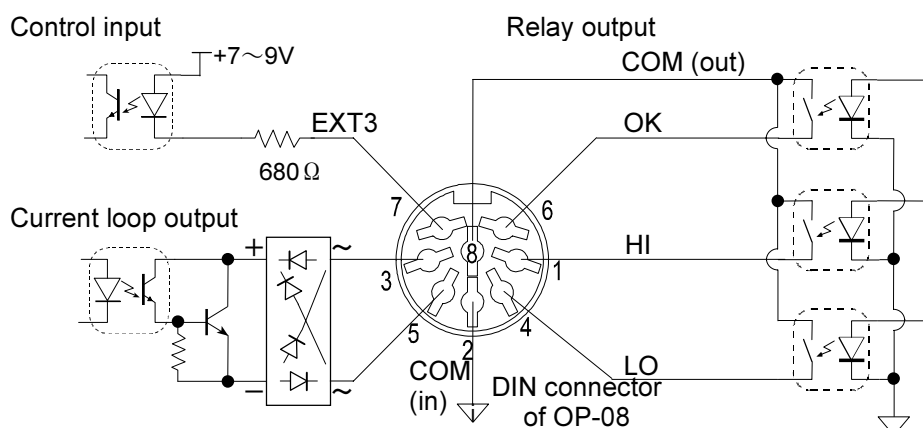

Current Loop Output

- The current loop output can be used to output data to an A&D printer and a display unit.
- The current loop output is of the passive type and requires an external current source of 20 mA current. A&D's printer and display unit can be connected without an external power source, because they supply the current.
- The output terminals do not have a polarity. Each output terminal can be connected to either the plus or minus inputs of the peripheral unit.

Data Format

- The data format is the same as that of the initial setting of F34 of RS-232C data format.
- The current loop output data format is fixed and can not be changed.
- Header 2 and the unit selection are common to RS-232C (CF06, CF07).

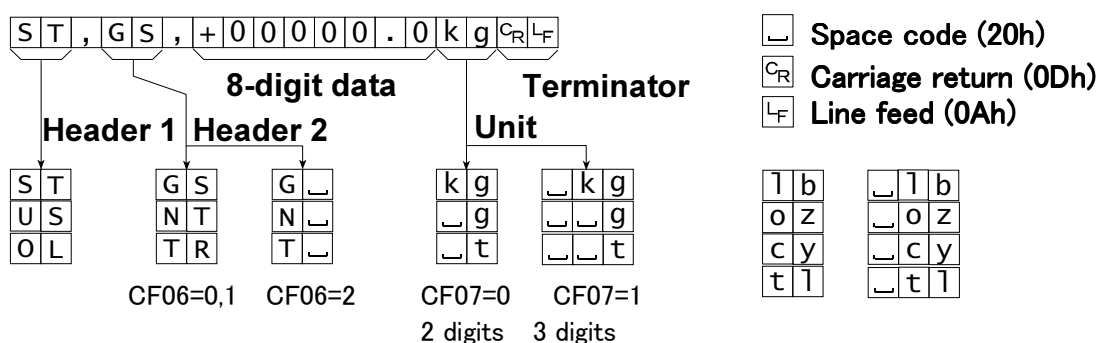



18. Specifications

Analog Input and A/D Conversion

Input sensitivity	Up to 0.2 μ V/division	
Input signal range	-1 mV to 15 mV	
Load cell excitation voltage	5V DC \pm 5%, 60 mA with sense voltage input	
Load cell drive capacity	Maximum 4 x 350 Ω load cells	
Temperature coefficient	Zero	$\pm(0.2 \mu\text{V} + 0.0008 \% \text{ of zero adjustment voltage})/^{\circ}\text{C}$ (typ.)
	Span	$\pm 0.0008\%/^{\circ}\text{C}$ of reading (typ.)
Non-linearity	0.01 % of full scale	
Maximum input noise	Less than 0.4 μ Vp-p	
Input impedance	10 M Ω or more	
A/D conversion method	Integrating dual slope type	
A/D resolution count	40000 counts	
A/D conversion rate	Approximately 10 times/s (unstable), 5 times/s(stable)	
Maximum display resolution	20000 (permissible 40000)	

Digital Section

Measurement display	7 segment, Liquid crystal display
Character height	25 mm
State indicator symbol	Minus sign, Zero point, Stable, Net, Comparison result Storing accumulated data, Percentage, Low battery Various state indicators (triangle 1, 2, 3)
Unit	kg, g, t (lb, oz, lb-oz / catty, tl, catty-tl : depends on the region)

Interface

RS-232C interface	Serial interface for communication (D-Sub 9P male contact)
RS-422/485 interface	Serial interface for communication, control (terminal block)
Current Loop output	20 mA, Passive type (DIN 8)
Analog output	4-20 mA, free scaling output (terminal block)
External Control Input	3 (or 1) contact input terminals, selected functions (DIN 8)
Relay output	3 point (DIN 8 or terminal block)
	Capacity: 50V AC/DC, maximum current 100 mA (resistive load)
	Comparison mode selection
	HiHi, Hi, OK, Lo, LoLo output for limit comparison
	Zero band, preliminary, free fall, final for setpoint comparison

General

Power supply	7 to 10VDC (AC adapter, dry battery (6 x C size), AD-1681)
Power consumption	Less than 10VA
Operation temperature	-10 $^{\circ}$ C to +40 $^{\circ}$ C (14 $^{\circ}$ F to 104 $^{\circ}$ F)
Operation humidity	85% R.H. (no condensation)
Mass	650 g approximately
Dimensions	192 (W) x 96 (H) x 86 (D) mm
Accessories	Refer to "4.4. Accessories"



18.1. Dimensions

